

BASE MODEL FREEZER (0°F)

Model: CFA68-D

68" Worktop Freezer with Drawers

Heavy gauge #300 Series stainless steel top, stainless steel front and end panels, galvanized steel rear and grill and aluminum interior.

Designed to maintain NSF-7 temperatures in 100°F ambient.



Options and Accessories

(upcharge and lead times may apply)

Doors in lieu of drawers	Condensing unit left or right
Drawer section above the condensing unit*	Remote models
Overshelves (single or double)	Door/drawer locks
Automatic, electric condensate evaporator	Adjustable legs
Exterior dial or digital thermometer	Front breathing
Stainless steel back and interior	

*Drawer section above condensing unit holds (1) 12 x 20 x 6 pan

Project Name:

Model Specified:

Location:

Item No:

Quantity:

AIA #:

SIS #:

Standard Model Features

REFRIGERATION SYSTEM

Performance-rated refrigeration system

Environmentally-safe R-404A refrigerant

Unique forced air design utilizes fans (approx. every 12") across the entire back of unit for even distribution of cold

Automatic, energy saving, non-electric condensate evaporator

Non-corrosive, plasticized fin evaporator coil

Easily serviceable, slide-out condensing unit

CABINET ARCHITECTURE

2" non-CFC polyurethane foam insulation

Spring loaded, self closing door (over condensing unit)

Magnetic snap-in door/drawer gaskets

Stainless steel roll-out drawers

5" casters

Completely enclosed, vented and removable rear and side grills

Refrigerated door section above the condensing unit

MODEL FEATURES

Expansion valve for quick recovery

Automatic electric defrost

Interior hanging thermometer

Field rehingeable door (over condensing unit)

NOTE: CFA-D models come standard with a door over the condensing unit. A drawer over the condensing unit is an option.

Continental
Refrigerator

Toll-Free: 800-523-7138
Phone: 215-244-1400
Fax: 215-244-9579

539 Dunksferry Road
Bensalem, PA 19020
www.continentalrefrigerator.com

APPROVAL:

Model Specifications

DIMENSIONAL DATA

Net Capacity (cu. ft.)	22 (623 cu l)
Width, Overall (in.)	68 (1727 mm)
Depth, Overall (in.) (incl. handles & bumpers)	36 1/16 (916 mm)
Height, Overall (in.) (incl. 5" casters)	35 (889 mm)
No. of Drawers	4
No. of Half Doors	1
Interior Depth (in.) (above condenser)	30 (762 mm)
Interior Height (in.) (above condenser)	12 1/2 (318 mm)
Interior Width (in.) (above condenser)	17 (432 mm)

REFRIGERANT DATA

Condensing Unit Size (H.P.)	1/2
Capacity (BTU/Hr)*	2310

ELECTRICAL DATA

Voltage (int'l)	115/60/1 (220/50/1)
Fans	2
Total Amps (int'l)	10.7 (4.9)
10 ft. Cord/Plug [attached] (int'l)	Yes (No)

SHIPPING DATA

Weight (lbs.)	490 (222 kg)
Height - Crated (in.)	43 3/4 (1111 mm)
Width - Crated (in.)	70 (1778 mm)
Depth - Crated (in.)	47 (1194 mm)

DRAWER PAN CONFIGURATIONS

Two Tier: (2) 12 x 20 x 6 pans per drawer

Three Tier: (1) 12 x 20 x 4 pan per drawer (top)
and (2) 12 x 20 x 4 pans per drawer (center & bottom)

* Rating @ -15°F evaporator, 90°F ambient

Figures in parentheses reflect metric equivalents rounded to the nearest whole unit.



Equipped with one NEMA-5-15P Plug
(varies by country)

Model Plan Views

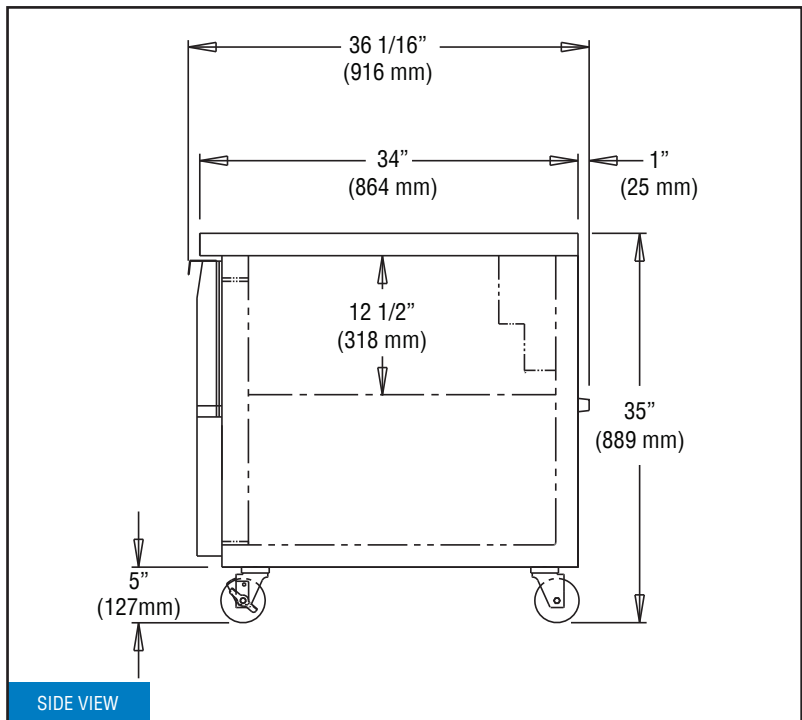
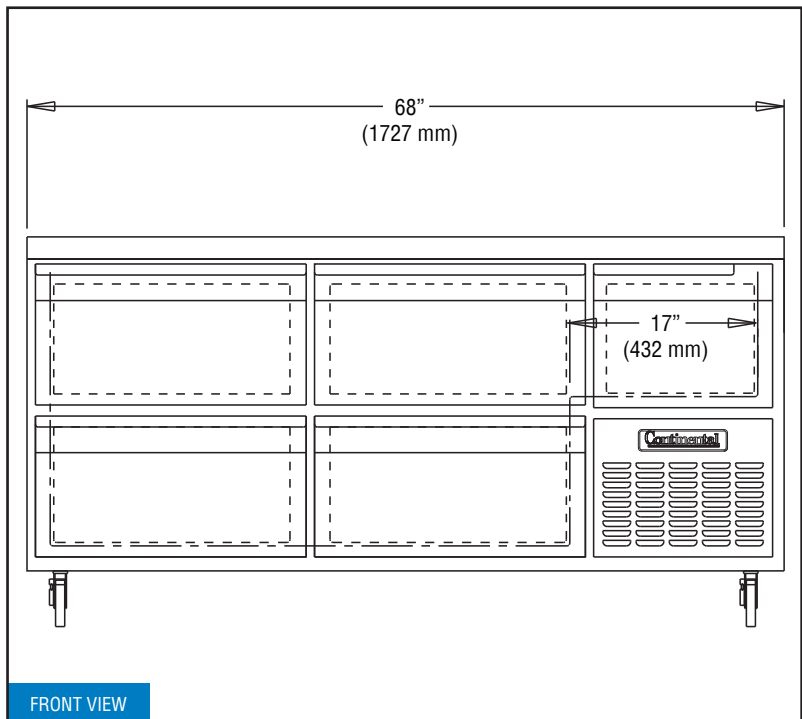

Continental
Refrigerator

Toll-Free: 800-523-7138
Phone: 215-244-1400
Fax: 215-244-9579

539 Dunkserry Road
Bensalem, PA 19020
www.continentalrefrigerator.com

Due to our continued efforts in developing innovative products, specifications subject to change without notice.



MADE IN THE U.S.A.

© Copyright 2015, Continental Refrigerator.
A Division of National Refrigeration & Air Conditioning Products, Inc.