

PIZZA PREPARATION TABLE

Model: CPA43

43" Pizza Preparation Refrigerator with Solid Doors

Heavy gauge #300 series stainless steel top, stainless steel front and end panels, aluminum interior.

Certified under NSF-7 to maintain temperatures in 86°F ambient and designed to maintain NSF-7 temperatures in 100°F ambient.



Options and Accessories

(upcharge and lead times may apply)

Stainless steel interior	Condensing unit left or right
Stainless steel back	Pan slides
Overshelves	Wire rod garnish rack
Add'l epoxy-coated steel shelves	Vision panel lid
Stainless steel shelves	Door locks
Automatic, electric condensate evaporator	Adjustable legs
Drawers in lieu of full door	Front breathing
Drawer in lieu of half door above the condensing unit*	Special electrical requirements (consult factory)

*Drawer section above condensing unit holds (1) 12 x 20 x 6 pan

Project Name:

Model Specified:

Location:

Item No:

Quantity:

AIA #:

SIS #:

Standard Model Features

REFRIGERATION SYSTEM

Performance-rated refrigeration system

Environmentally-safe R-134a refrigerant

Unique forced air design utilizes fans (approx. every 12") across the entire back of unit for even distribution of cold

Automatic, energy saving, non-electric condensate evaporator

Non-corrosive, plasticized fin evaporator coil

Easily serviceable, slide-out condensing unit

CABINET ARCHITECTURE

2" non-CFC polyurethane foam insulation

Spring loaded, self closing doors

Magnetic snap-in door gaskets

Heavy-duty, epoxy-coated steel shelves

19" deep, full length nylon cutting board

Refrigerated section w/door above the condensing unit

Insulated lid

5" casters

MODEL FEATURES

Electronic controller w/digital display & hi-low alarm

Ergonomically-friendly raised angle rail

Expansion valve for quick recovery

Built-in, off cycle defrost timer assures optimum coil defrost

Field rehingeable doors

NOTE: CPA models come standard with a door above the condensing unit. A drawer above the condensing unit is an option.

Continental
Refrigerator

Toll-Free: 800-523-7138
Phone: 215-244-1400
Fax: 215-244-9579

539 Dunksferry Road
Bensalem, PA 19020
www.continentalrefrigerator.com

APPROVAL:

Model Specifications

DIMENSIONAL DATA

Net Capacity (cu. ft.)	12 (340 cu l)
Width, Overall (in.)	43 (1092 mm)
Depth, Overall (in.) (incl. cutting board & bumpers)	36 7/8 (937 mm)
Height, Overall (in.) (incl. 5" casters)	39 7/16 (1002 mm)
Depth, Cutting Board (in.)	19 (483 mm)
Pan Capacity (pans supplied by others)	(4) 1/3 / (1) 1/2
Shelf Area (sq. ft.)	5.6 (.5 sq m)
No. of Shelves	1
No. of Full Doors	1
No. of Half Doors	1
Interior Depth (in.)	27 3/8 (695 mm)
Interior Height (in.)	26 (660 mm)
Interior Height (in.) (above condenser)	12 1/2 (318 mm)
Interior Width (in.)	39 (991 mm)

REFRIGERANT DATA

Condensing Unit Size (H.P.)	1/3
Capacity (BTU/Hr)*	2610

ELECTRICAL DATA

Voltage (int'l)	115/60/1 (220/50/1)
Fans	3
Total Amps (int'l)	6.7 (3.2)
10 ft. Cord/Plug [attached] (int'l)	Yes (No)

SHIPPING DATA

Weight (lbs.)	355 (161 kg)
Height - Crated (in.)	43 3/4 (1111 mm)
Width - Crated (in.)	45 (1143 mm)
Depth - Crated (in.)	47 (1194 mm)

* Rating @ +25°F evaporator, 90°F ambient

Figures in parentheses reflect metric equivalents rounded to the nearest whole unit.



Equipped with one NEMA-5-15P Plug
(varies by country)

Continental
Refrigerator

Toll-Free: 800-523-7138
Phone: 215-244-1400
Fax: 215-244-9579

539 Dunkserry Road
Bensalem, PA 19020
www.continentalrefrigerator.com

Due to our continued efforts in developing innovative products, specifications subject to change without notice.



MADE IN THE U.S.A.

© Copyright 2018. Continental Refrigerator.
A Division of National Refrigeration & Air Conditioning Products, Inc.

Model Plan Views

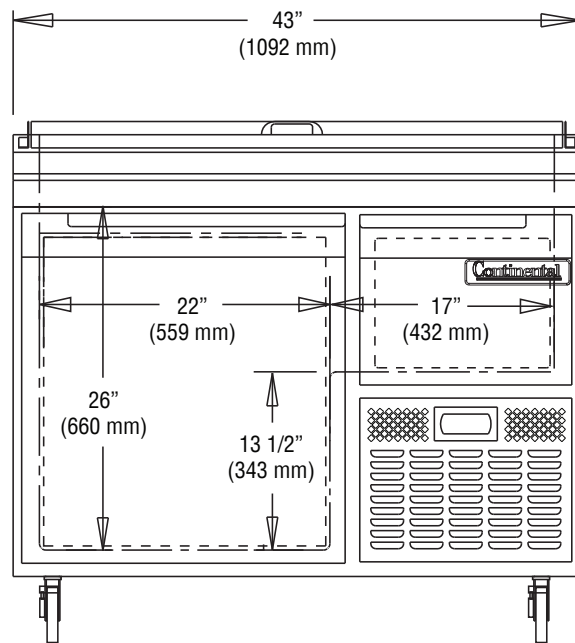

FRONT VIEW

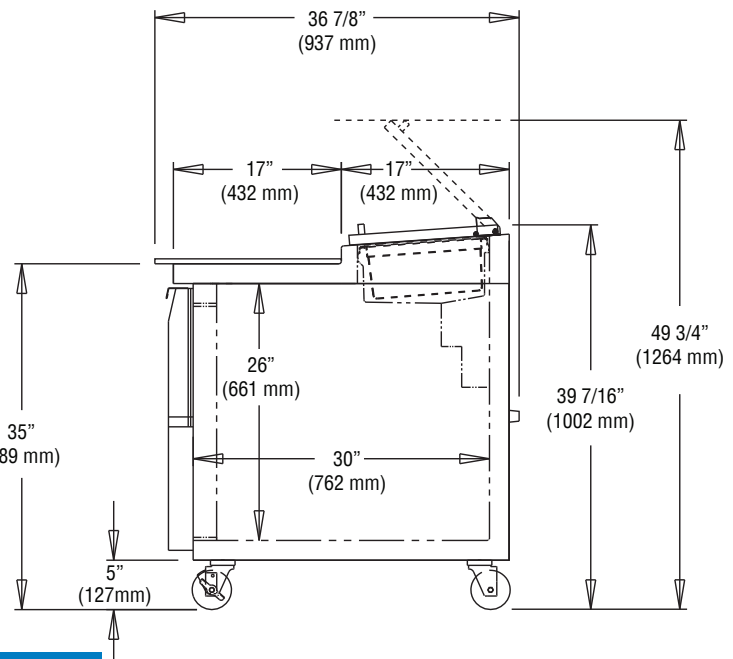

SIDE VIEW

IMPORTANT NOTE: If the cabinet is located directly against a wall, a minimum clearance of 3" is required on sides, front and rear.