

# BASE UNDERCOUNTER REFRIGERATOR

## Model: CRA60-U-D

### 60" Base Undercounter Refrigerator with Drawers (Door on Smaller Width Section)

Heavy gauge #300 Series stainless steel top, stainless steel front and end panels, galvanized steel rear and grill and aluminum interior.

Designed to maintain NSF-7 temperatures in 100°F ambient.



### Options and Accessories

(upcharge and lead times may apply)

|   |  |
|---|--|
| Stainless steel interior                              | Condensing unit left or right                              |
| Stainless steel back                                  | Automatic, electric condensate evaporator                  |
| Door in lieu of drawers (large section)               | Door/drawer locks  |
| Drawer in lieu of half door above the condensing unit | Special electrical requirements ( <i>consult factory</i> ) |

\*Drawer section above condensing unit holds (1) 12 x 20 x 6 pan

Project Name:

Model Specified:

Location:

Item No:

Quantity:

AIA #:

SIS #:

### Standard Model Features

#### REFRIGERATION SYSTEM

Performance-rated refrigeration system

Environmentally-safe R-134a refrigerant

Unique forced air design utilizes fans (approx. every 12") across the entire back of unit for even distribution of cold

Automatic, energy saving, non-electric condensate evaporator

Non-corrosive, plasticized fin evaporator coil

Easily serviceable, slide-out condensing unit

#### CABINET ARCHITECTURE

2" non-CFC polyurethane foam insulation

Spring loaded, self closing doors (smaller section and over condensing unit)

Magnetic snap-in door/drawer gaskets

Stainless steel roll-out drawers (larger section)

Completely enclosed, vented and removable rear and side grills

Refrigerated section with door above the condensing unit (8) 1 3/8" diameter plate casters mounted on heavy-duty support plates (easily field installed)

#### MODEL FEATURES

Electronic controller w/ digital display & hi-low alarm

Front breather air divider (field installed)

Expansion valve for quick recovery

Built-in, off-cycle defrost timer

**NOTE:** CRA60-U-D models come standard with a door over the condensing unit, a solid door (left section) and two tier drawers (center section). The option of having the door/drawers located in the opposite sections **MUST** be indicated at the time of ordering. A drawer over the condensing unit is an option.

**Continental**  
Refrigerator

Toll-Free: 800-523-7138  
Phone: 215-244-1400  
Fax: 215-244-9579

539 Dunksferry Road  
Bensalem, PA 19020  
www.continentalrefrigerator.com

APPROVAL:

## Model Specifications

### DIMENSIONAL DATA

|   |                  |
|---|------------------|
| Net Capacity (cu. ft.)                                | 19 (538 cu l)    |
| Width, Overall (in.)                                  | 60 (1524 mm)     |
| Depth, Overall (in.)<br>(incl. handles & bumpers)     | 36 1/16 (916 mm) |
| Height, Overall (in.)<br>(incl. 1 3/8" plate casters) | 31 3/4 (806 mm)  |
| Shelf Area (sq. ft.)                                  | 5.6 (.5 sq m)    |
| No. of Shelves  | 2                |
| No. of Drawers  | 2                |
| No. of Full Doors                                     | 1                |
| No. of Half Doors                                     | 1                |
| Interior Depth (in.) (above condenser)                | 30 (762 mm)      |
| Interior Height (in.) (smaller section)               | 26 (660 mm)      |
| Interior Height (in.) (above condenser)               | 12 1/2 (318 mm)  |
| Interior Width (in.) (smaller section)                | 17 (422 mm)      |
| Interior Width (in.) (above condenser)                | 17 (1422 mm)     |

### REFRIGERANT DATA

|                             |      |
|-----------------------------|------|
| Condensing Unit Size (H.P.) | 1/3  |
| Capacity (BTU/Hr)*          | 3100 |

### ELECTRICAL DATA

|                                     |                     |
|-------------------------------------|---------------------|
| Voltage (int'l)                     | 115/60/1 (220/50/1) |
| Fans                                | 3                   |
| Total Amps (int'l)                  | 12.3 (8.1)          |
| 10 ft. Cord/Plug [attached] (int'l) | Yes (No)            |

### SHIPPING DATA

|                       |                  |
|-----------------------|------------------|
| Weight (lbs.)         | 405 (184 kg)     |
| Height - Crated (in.) | 43 3/4 (1111 mm) |
| Width - Crated (in.)  | 62 (1575 mm)     |
| Depth - Crated (in.)  | 47 (1194 mm)     |

### DRAWER PAN CONFIGURATIONS

**Two Tier:** (2) 12 x 20 x 4 pans (top)  
and (2) 12 x 20 x 6 pans (bottom)

**Three Tier:** (1) 12 x 20 x 4 pan (top)  
and (2) 12 x 20 x 4 pans per drawer (center & bottom)

\* Rating @ +25°F evaporator, 90°F ambient

Figures in parentheses reflect metric equivalents rounded to the nearest whole unit.

## Model Plan Views

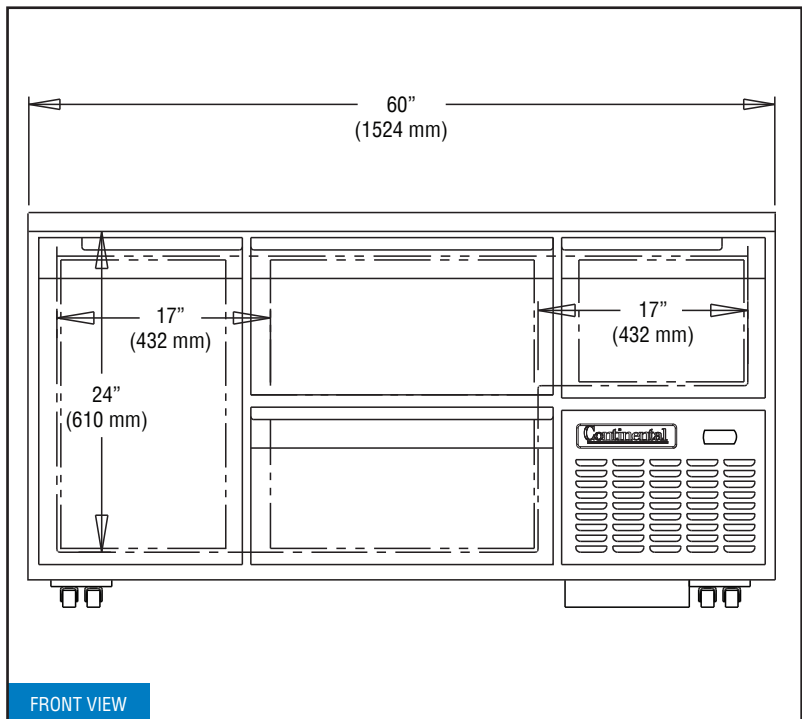

FRONT VIEW

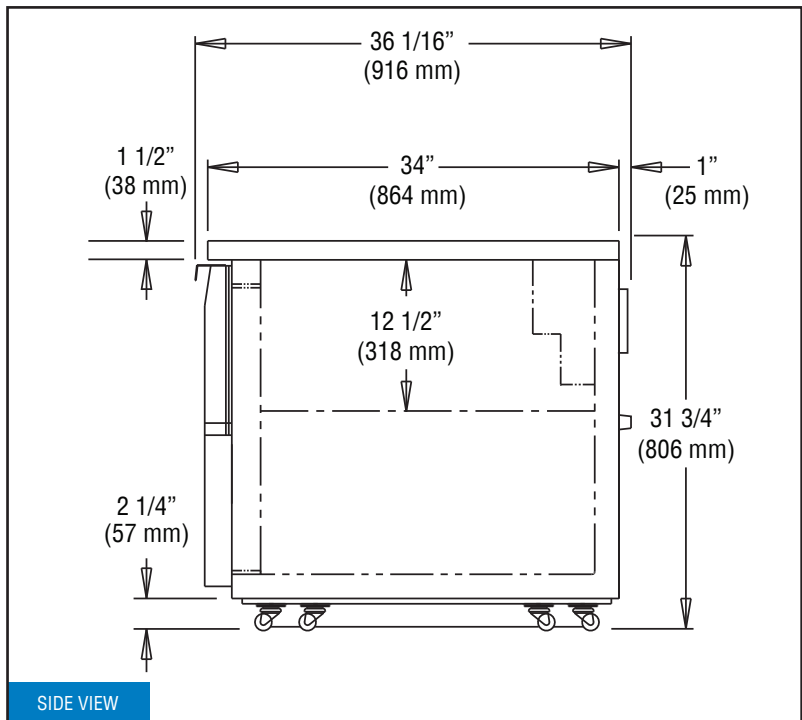

SIDE VIEW

**Continental**  
Refrigerator

Toll-Free: 800-523-7138  
Phone: 215-244-1400  
Fax: 215-244-9579

539 Dunkserry Road  
Bensalem, PA 19020  
[www.continentalrefrigerator.com](http://www.continentalrefrigerator.com)

Due to our continued efforts in developing innovative products, specifications subject to change without notice.



MADE IN THE U.S.A.

© Copyright 2017. Continental Refrigerator.  
A Division of National Refrigeration & Air Conditioning Products, Inc.



Equipped with one NEMA-5-15P Plug  
(varies by country)

CRA60-U-D (7/10/17)