

# DESIGNER LINE REFRIGERATOR

**Model: DL1R**

## 1-Section Reach-In Refrigerator

**DL1R** - Stainless steel front, aluminum end panels and interior  
**DL1R-SA** - Stainless steel exterior, aluminum interior  
**DL1R-SS** - Stainless steel exterior and interior  
**Designed to maintain NSF-7 temperatures in 100°F ambient.**



*Designer Line*

### Options and Accessories

(upcharge and lead times may apply)

Stainless steel case back	Pass-Thru
Add'l epoxy-coated steel shelves	Shallow depth
Chrome or stainless steel shelves	Hinged glass door
Heavy-duty pilaster strips	Increased refrigeration systems
Pan slide assemblies	Special electrical req. (consult factory)
Expansion valve system	<b>Correctional Facility Options</b>
Wine display	<ul style="list-style-type: none"> <li>One way security screws</li> </ul>
Adjustable legs	<ul style="list-style-type: none"> <li>Locking hasp (lock not included)</li> </ul>
Custom laminates	<ul style="list-style-type: none"> <li>Stainless steel mesh cover</li> </ul>
Half doors	<ul style="list-style-type: none"> <li>Coverless hinges</li> </ul>

Consult factory for other model configurations, options and accessories.

**Continental**<sup>®</sup>  
**Refrigerator**

Toll-Free: 800-523-7138  
 Phone: 215-244-1400  
 Fax: 215-244-9579

539 Dunksferry Road  
 Bensalem, PA 19020  
[www.continentalrefrigerator.com](http://www.continentalrefrigerator.com)

Project Name:

Model Specified:

Location:

Item No:

Quantity:

AIA #:

SIS #:

### Standard Model Features

#### REFRIGERATION SYSTEM

Environmentally-safe R-134a refrigerant

Self contained, performance-rated "plug" refrigeration system

Refrigeration system is readily accessible on top of cabinet, separate from the "food zone" to increase storage capacity

Automatic, hot gas condensate evaporator

#### CABINET ARCHITECTURE

3" non-CFC polyurethane foam insulation

Smooth, polished chrome workflow door handle

Cam action, lift off hinges

Self-closing door

Magnetic snap-in door gasket

Cylinder lock in door

Heavy-duty, epoxy-coated steel shelves

Adjustable 6" stainless steel legs

#### MODEL FEATURES

LED interior lighting

Electronic controller w/ digital display & hi-low alarm

Unique air duct system for optimum air flow

Cabinet upper side panels and refrigeration "plug" system can be easily removed and reinstalled at job site

Rehinging of door (in the field)

APPROVAL:

## Model Specifications

### DIMENSIONAL DATA

Net Capacity (cu. ft.)	21 (595 cu l)
Width, Overall (in.)	26 (660 mm)
Depth, Overall (incl. handle) (in.)	35 3/8 (899 mm)
Depth [less door] (in.)	32 (813 mm)
Depth [door open 90°] (in.)	55 1/2 (1410 mm)
Clear Door Width (in.)	19 3/8 (492 mm)
Clear Door Height (in.)	58 5/8 (1489 mm)
Height, Overall (incl. 6" legs) (in.)	83 1/4 (2115 mm)
No. of Doors	1
No. of Shelves	3
Shelf Area (sq. ft.)	20.4 (1.9 sq m)
Tray Slide Capacity	24 ea.

### REFRIGERANT DATA

Condensing Unit Size (H.P.)	1/4
Capacity (BTU/Hr)*	1940

### ELECTRICAL DATA

Voltage (int'l)	115/60/1 (220/50/1)
Feed Wires (incl. ground)	3
Total Amps (int'l)	5.5 (3.5)
10 ft. Cord/Plug [attached] (int'l)	Yes (No)

### SHIPPING DATA

Height - Crated (in.)	85 1/2 (2172 mm)
Width - Crated (in.)	31 5/8 (803 mm)
Depth - Crated (in.)	42 (1067 mm)
Volume - Crated (cu. ft.)	65 (1841 cu l)
Weight Std - Crated (lbs.)	320 (145 kg)
Weight SS - Crated (lbs.)	380 (172 kg)
Weight Std - Uncrated (lbs.)	220 (100 kg)
Weight SS - Uncrated (lbs.)	280 (127 kg)

\* Rating @ +25°F evaporator, 90°F ambient

Figures in parentheses reflect metric equivalents rounded to the nearest whole unit.



Equipped with one NEMA-5-15P Plug  
(varies by country)

**Continental**  
Refrigerator

Toll-Free: 800-523-7138  
Phone: 215-244-1400  
Fax: 215-244-9579

539 Dunksferry Road  
Bensalem, PA 19020  
[www.continentalrefrigerator.com](http://www.continentalrefrigerator.com)

Due to our continued efforts in developing innovative products, specifications subject to change without notice.



Intertek



MADE IN THE U.S.A.

© Copyright 2017, Continental Refrigerator.  
A Division of National Refrigeration & Air Conditioning Products, Inc.

## Model Plan Views

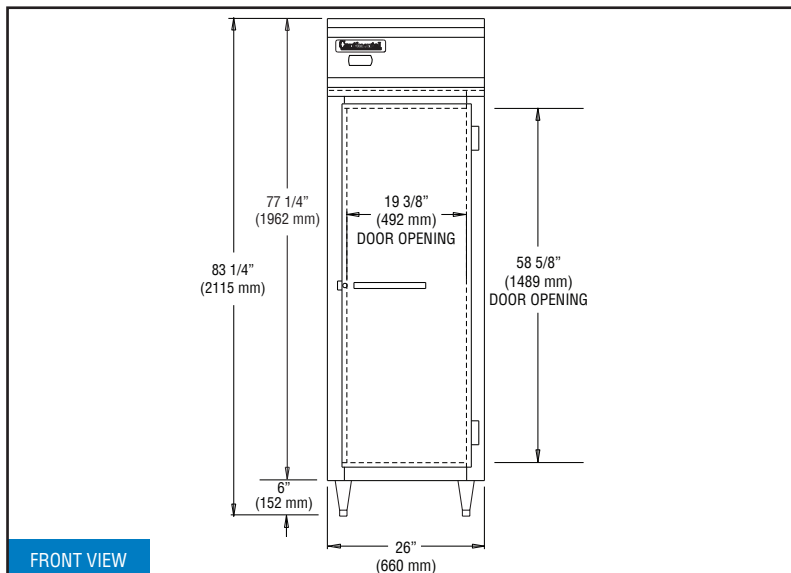

FRONT VIEW

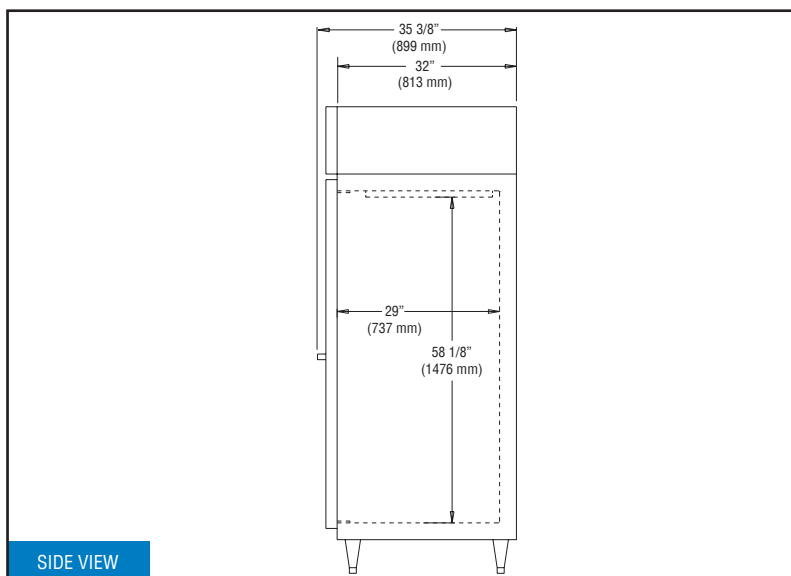

SIDE VIEW

**IMPORTANT NOTE:** If the cabinet is located directly against a wall and/or under a low ceiling, a minimum clearance of 12" is required on top and 3" on sides and rear.

### REFRIGERATION SYSTEM

A "performance rated", air-cooled, hermetically sealed, capillary-type refrigeration system is installed on the top of each refrigerator. Plasticized fin coil and air circulation fans are contained within a concealed "plug"-type insulated housing, readily accessible on top of the cabinet and separate from the food zone to increase food storage capacity. The entire "plug" system is fully charged with environmentally safe R-134a refrigerant and mounted on a sturdy steel, rail-type base which can be easily removed if freezer conversion is desired. Refrigerators are designed to maintain 38°F-40°F (3°-5° Centigrade) while operating with an unrestricted air supply in a maximum ambient temperature of 100°F. All condensate water is evaporated by an automatic, non-electric, corrosion-resistant condensate evaporator. A strict quality-assurance team inspects all materials and components to certify that each model conforms to the most exacting standards. All models are factory performance-tested for a minimum of 12 hours prior to crating.

### INSULATION

All cabinet walls, top and bottom have high density, foamed-in-place, non-CFC polyurethane insulation.

### SHELVING

Shelves are designed for heavy-duty use with .306" diameter frame and brace members and .140" diameter fill wires spaced 3/4" apart. Shelves are welded steel and epoxy-coated for a durable, long, rust-free service life. Adjustments are in 1 inch increments and a wide door opening allows the use of a variety of optional pan and tray slide types.

### CABINET CONSTRUCTION

All materials are of top quality, assembled to conform with strict quality-assurance requirements. The cabinet front is constructed of heavy-gauge polished stainless steel for durability. All cabinet joints and seams are sealed vapor-tight. Case is of all metal, welded construction and internally supported and braced for a rigid unit construction. Cabinet design eliminated overlapping panels with raw edges. Cabinet body is insulated with non-CFC, foamed-in-place polyurethane foam with an average thickness of 3 inches to ensure increased energy efficiency. Full-length louvered air grille located above the doors allows equal air circulation to the condensing unit. Easily removable, low-wattage, anti-sweat door heaters concealed by a non-metallic, non-conductive, high-impact thermal breaker strip eliminate condensate build-up on the cabinet front. Cabinets are equipped with 6 inch adjustable stainless steel legs.

### DOOR CONSTRUCTION

Solid hinged door shells are constructed of heavy-gauge stainless steel and are internally braced and urethane-foam-insulated for rigidity. Door corners are welded construction and polished. Replaceable snap-in door gaskets are self-adjusting, heavy-duty, magnetic type. Door handles and hinges are chrome-plated and non-corrosive. Doors are provided with built-in cylinder locks which are keyed alike. Hinges are cam action, lift-off type featuring positive safety stop at 120 degrees.