

DESIGNER LINE SLIM LINE REFRIGERATOR

Model: DL1RSE-HD

1-Section Slim Line Reach-In Refrigerator with Half Doors

DL1RSE-HD - Stainless steel front, aluminum end panels and interior
DL1RSE-SA-HD - Stainless steel exterior, aluminum interior
DL1RSE-SS-HD - Stainless steel exterior and interior



Options and Accessories

(upcharge and lead times may apply)

Stainless steel case back	Shallow depth
Additional epoxy-coated steel shelves	Hinged glass doors
Chrome or stainless steel shelves	Increased refrigeration systems
Expansion valve system	Special electrical req. (consult factory)
Wine display	Correctional Facility Options
Casters	• One way security screws
Dial thermometer	• Locking hasp (lock not included)
Remote models	• Stainless steel mesh cover
Custom laminates	• Coverless hinges
Full door	

Consult factory for other model configurations, options and accessories.

Continental
Refrigerator

Toll-Free: 800-523-7138
 Phone: 215-244-1400
 Fax: 215-244-9579

539 Dunksferry Road
 Bensalem, PA 19020
www.continentalrefrigerator.com

Project Name:

Model Specified:

Location:

Item No:

Quantity:

AIA #:

SIS #:

Standard Model Features

REFRIGERATION SYSTEM

Environmentally-safe R-134a refrigerant

Self contained, performance-rated refrigeration system

Automatic, electric condensate evaporator*

CABINET ARCHITECTURE

2" non-CFC polyurethane foam insulation

Chrome-plated flow line handles

Cam action, lift off hinges

Self-closing doors

Magnetic snap-in door gaskets

Cylinder lock in door

Heavy-duty, epoxy-coated steel shelves

Adjustable 6" stainless steel legs

MODEL FEATURES

Automatic interior lighting

External digital thermometer

Energy saving switch for door heaters

Will accommodate 12 x 20 pans

Rehinging of doors (in the field)

* Coil housing in cabinet zone and automatic, electric condensate in lieu of hot gas condensate.

APPROVAL:

Model Specifications

DIMENSIONAL DATA

Net Capacity (cu. ft.)	15 (425 cu l)
Width, Overall (in.)	17 3/4 (451 mm)
Depth, Overall (incl. handles) (in.)	35 3/8 (899 mm)
Depth [less doors] (in.)	32 (813 mm)
Depth [doors open 90°] (in.)	47 3/8 (1203 mm)
Clear Door Width (in.)	13 1/8 (333 mm)
Clear Half Door Height (in.)	28 1/2 (724 mm)
Height, Overall (incl. 6" legs) (in.)	83 1/4 (2115 mm)
No. of Half Doors	2
No. of Shelves	5
Shelf Area (sq. ft.)	9.3 (.9 sq m)

REFRIGERANT DATA

Condensing Unit Size (H.P.)	1/4
Capacity (BTU/Hr)*	1940

ELECTRICAL DATA

Voltage (int'l)	115/60/1 (220/50/1)
Feed Wires (incl. ground)	3
Total Amps (int'l)	5.5 (3.4)
10 ft. Cord/Plug [attached] (int'l)	Yes (No)

SHIPPING DATA

Height - Crated (in.)	85 1/2 (2172 mm)
Width - Crated (in.)	32 (813 mm)
Depth - Crated (in.)	42 (1067 mm)
Volume - Crated (cu. ft.)	65 (1841 cu l)
Weight Std - Crated (lbs.)	290 (132 kg)
Weight SS - Crated (lbs.)	350 (159 kg)
Weight Std - Uncrated (lbs.)	190 (86 kg)
Weight SS - Uncrated (lbs.)	250 (113 kg)

* Rating @ +25°F evaporator, 90°F ambient

Figures in parentheses reflect metric equivalents rounded to the nearest whole unit.



Equipped with one NEMA-5-15P Plug
(varies by country)

Continental

Refrigerator

Toll-Free: 800-523-7138
Phone: 215-244-1400
Fax: 215-244-9579

539 Dunksferry Road
Bensalem, PA 19020
www.continentalrefrigerator.com

Due to our continued efforts in developing innovative products, specifications subject to change without notice.



© Copyright 2013. Continental Refrigerator.
A Division of National Refrigeration & Air Conditioning Products, Inc.

Model Plan Views

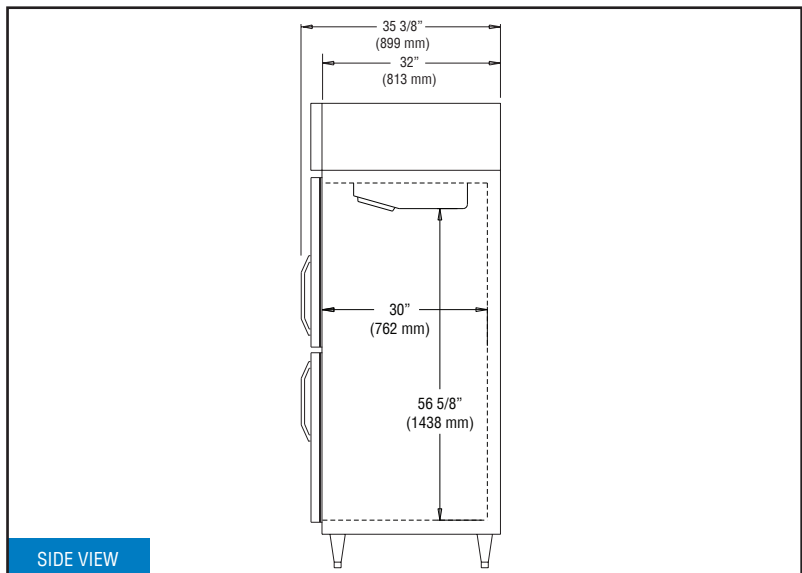
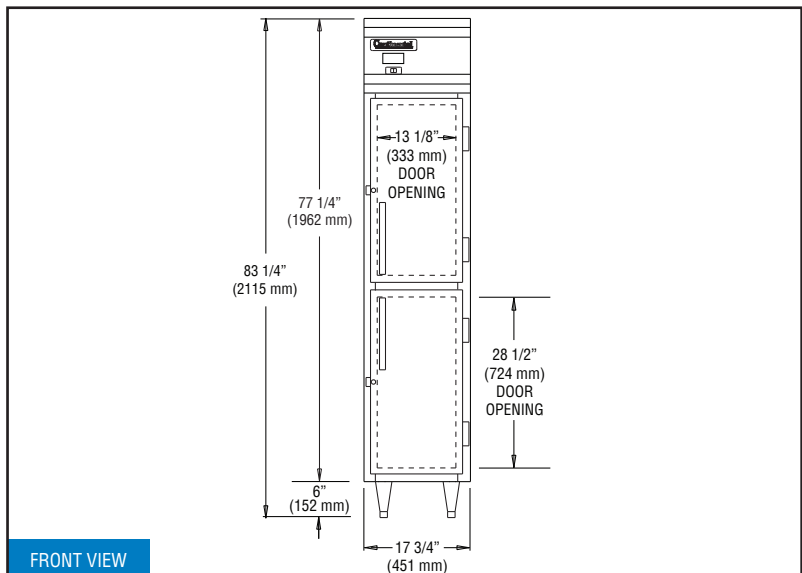

IMPORTANT NOTE: If the cabinet is located directly against a wall and/or under a low ceiling, a minimum clearance of 12" is required.

REFRIGERATION SYSTEM

A "performance rated", air-cooled, hermetically sealed, capillary-type refrigeration system is installed on the top of each refrigerator. Plasticized fin coil and air circulation fans are contained within an easily accessible, low-profile, interior ceiling mounted housing. Refrigeration system is fully charged with environmentally safe R-134a refrigerant. Refrigerators are designed to maintain 38°F-40°F (3°-5° Centigrade) while operating with an unrestricted air supply in a maximum ambient temperature of 100°F. All condensate water is directed to the cabinet bottom for connection to an automatic thermostatically-controlled evaporator which is supplied with each model. A strict quality-assurance team inspects all materials and components to certify that each model conforms to the most exacting standards. All models are factory performance tested for a minimum of 16 hours prior to crating.

INSULATION

All cabinet walls, top and bottom have high density, foamed-in-place, non-CFC polyurethane insulation.

SHELVING

Shelves are designed for heavy-duty use with .306" diameter frame and brace members and .140" diameter fill wires spaced 3/4" apart. Shelves are welded steel and epoxy-coated for a durable, long, rust-free service life. Adjustments are in 1 inch increments and will accommodate 12 x 20 pans.

CABINET CONSTRUCTION

All materials are of top quality, assembled to conform with strict quality-assurance requirements. The cabinet front is constructed of heavy-gauge polished stainless steel for durability. All cabinet joints and seams are sealed vapor-tight. Case is of all metal, welded construction and internally supported and braced for a rigid unit construction. Cabinet design eliminates overlapping panels with raw edges. Cabinet body is insulated with non-CFC, foamed-in-place polyurethane foam with an average thickness of 2 inches to ensure increased energy efficiency. Full-length louvered air grille located above the door allows equal air circulation to the condensing unit. Easily removable, low-wattage, anti-sweat door heater concealed by a non-metallic, non-conductive, high-impact thermal breaker strip eliminates condensate build-up on the cabinet front. Automatic interior lighting is activated by an easily accessible interior switch. Cabinet is equipped with 6 inch adjustable stainless steel legs.

DOOR CONSTRUCTION

Solid hinged door shells are constructed of heavy-gauge stainless steel and are internally braced and urethane-foam-insulated for rigidity. Door corners are welded construction and polished. Replaceable snap-in door gaskets are self-adjusting, heavy-duty, magnetic type. Door handles and hinges are chrome-plated and non-corrosive. Doors are provided with built-in cylinder lock. Hinges are cam action, lift-off type featuring positive safety stop at 120 degrees.