

DESIGNER LINE REFRIGERATOR

Model: DL2RE-PT

2-Section Extra-Wide Pass-Thru Refrigerator

DL2RE-PT - Stainless steel front, aluminum end panels and interior
DL2RE-SA-PT - Stainless steel exterior, aluminum interior
DL2RE-SS-PT - Stainless steel exterior and interior



Options and Accessories

(upcharge and lead times may apply)

| | |
|---------------------------------------|--|
| Stainless steel case back | Full doors |
| Additional epoxy-coated steel shelves | Reach-In |
| Chrome or stainless steel shelves | Shallow depth |
| Pan slide assemblies | Hinged glass doors |
| Rehinging of doors (consult factory) | Increased refrigeration systems |
| Expansion valve system | Special electrical req. (consult factory) |
| Wine display | Correctional Facility Options |
| Casters | <ul style="list-style-type: none"> One way security screws |
| Dial thermometer | <ul style="list-style-type: none"> Locking hasp (lock not included) |
| Remote models | <ul style="list-style-type: none"> Stainless steel mesh cover |
| Custom laminates | <ul style="list-style-type: none"> Coverless hinges |

Consult factory for other model configurations, options and accessories.

Continental
Refrigerator

Toll-Free: 800-523-7138
 Phone: 215-244-1400
 Fax: 215-244-9579

539 Dunksferry Road
 Bensalem, PA 19020
www.continentalrefrigerator.com

Project Name:

Model Specified:

Location:

Item No:

Quantity:

AIA #:

SIS #:

Standard Model Features

REFRIGERATION SYSTEM

Environmentally-safe R-134a refrigerant

Self contained, performance-rated "plug" refrigeration system

Refrigeration system is readily accessible on top of cabinet, separate from the "food zone" to increase storage capacity

Automatic, hot gas condensate evaporator

CABINET ARCHITECTURE

3" non-CFC polyurethane foam insulation

Chrome-plated flow line handles

Cam action, lift off hinges

Self-closing doors

Magnetic snap-in door gaskets

Cylinder lock in door

Heavy-duty, epoxy-coated steel shelves

Adjustable 6" stainless steel legs

MODEL FEATURES

Automatic interior lighting

External digital thermometer

Energy saving switch for door heaters

Unique air duct system for optimum air flow

Cabinet upper side panels and refrigeration "plug" system can be easily removed and reinstalled at job site

APPROVAL:

Model Specifications

DIMENSIONAL DATA

| | |
|---------------------------------------|------------------|
| Net Capacity (cu. ft.) | 52 (1472 cu l) |
| Width, Overall (in.) | 57 (1448 mm) |
| Depth, Overall (incl. handles) (in.) | 38 3/4 (984 mm) |
| Depth [less doors] (in.) | 32 (813 mm) |
| Depth [doors open 90°] (in.) | 84 (2134 mm) |
| Clear Door Width (in.) | 21 7/8 (556 mm) |
| Clear Door Height (in.) | 58 5/8 (1489 mm) |
| Height, Overall (incl. 6" legs) (in.) | 83 1/4 (2115 mm) |
| No. of Doors | 4 |
| No. of Shelves | 6 |
| Shelf Area (sq. ft.) | 40.8 (3.8 sq m) |
| Tray Slide Capacity | 24 ea. |

REFRIGERANT DATA

| | |
|-----------------------------|------|
| Condensing Unit Size (H.P.) | 1/3 |
| Capacity (BTU/Hr)* | 2560 |

ELECTRICAL DATA

| | |
|-------------------------------------|---------------------|
| Voltage (int'l) | 115/60/1 (220/50/1) |
| Feed Wires (incl. ground) | 3 |
| Total Amps (int'l) | 6.9 (5.3) |
| 10 ft. Cord/Plug [attached] (int'l) | Yes (No) |

SHIPPING DATA

| | |
|------------------------------|------------------|
| Height - Crated (in.) | 85 1/2 (2172 mm) |
| Width - Crated (in.) | 64 (1626 mm) |
| Depth - Crated (in.) | 42 (1067 mm) |
| Volume - Crated (cu. ft.) | 133 (3766 cu l) |
| Weight Std - Crated (lbs.) | 645 (293 kg) |
| Weight SS - Crated (lbs.) | 715 (324 kg) |
| Weight Std - Uncrated (lbs.) | 465 (211 kg) |
| Weight SS - Uncrated (lbs.) | 545 (247 kg) |

* Rating @ +25°F evaporator, 90°F ambient

Figures in parentheses reflect metric equivalents rounded to the nearest whole unit.



Equipped with one NEMA-5-15P Plug
(varies by country)

Continental

Refrigerator

Toll-Free: 800-523-7138
Phone: 215-244-1400
Fax: 215-244-9579

539 Dunksferry Road
Bensalem, PA 19020
www.continentalrefrigerator.com

Due to our continued efforts in developing innovative products, specifications subject to change without notice.



© Copyright 2013. Continental Refrigerator.
A Division of National Refrigeration & Air Conditioning Products, Inc.

Model Plan Views

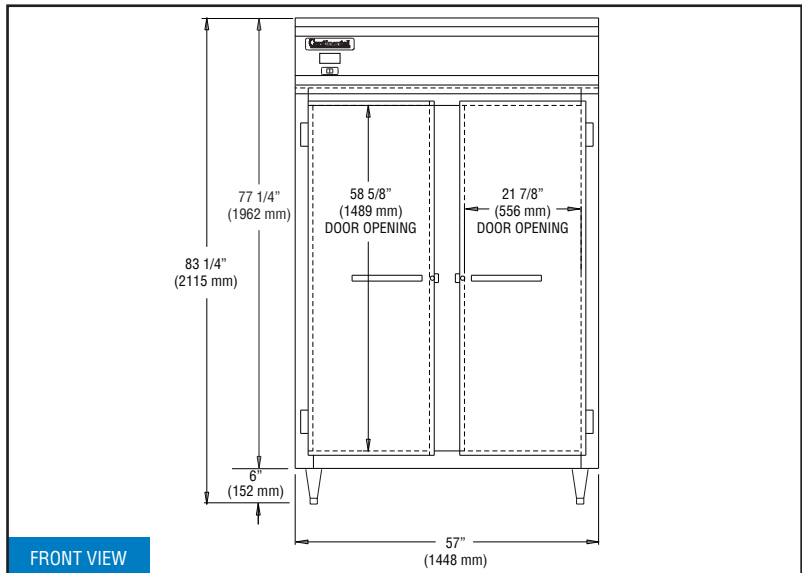

FRONT VIEW

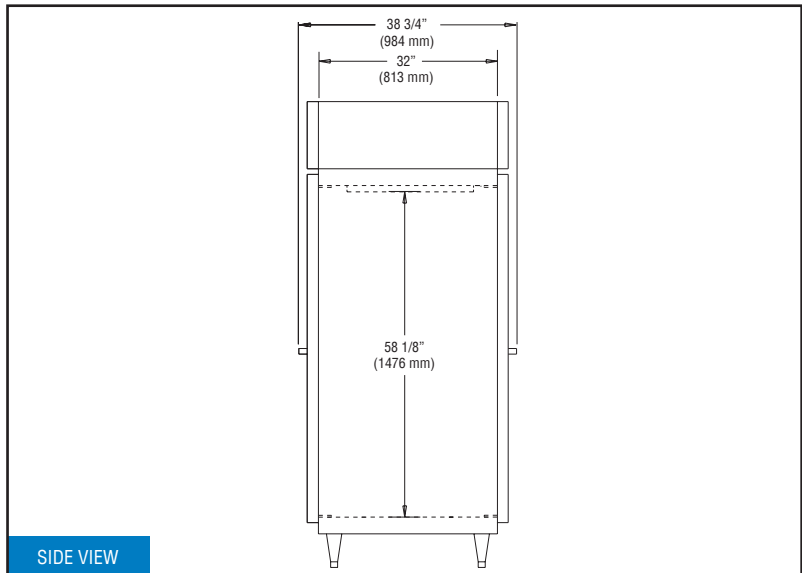

SIDE VIEW

IMPORTANT NOTE: If the cabinet is located directly against a wall and/or under a low ceiling, a minimum clearance of 12" is required.

REFRIGERATION SYSTEM

A "performance rated", air-cooled, hermetically sealed, capillary-type refrigeration system is installed on the top of each refrigerator. Plasticized fin coil and air circulation fans are contained within a concealed "plug"-type insulated housing, readily accessible on top of the cabinet and separate from the food zone to increase food storage capacity. The entire "plug" system is fully charged with environmentally safe R-134a refrigerant and mounted on a sturdy steel, rail-type base which can be easily removed if freezer conversion is desired. Refrigerators are designed to maintain 38°F-40°F (3°-5° Centigrade) while operating with an unrestricted air supply in a maximum ambient temperature of 100°F. All condensate water is evaporated by an automatic, non-electric, corrosion-resistant condensate evaporator. A strict quality-assurance team inspects all materials and components to certify that each model conforms to the most exacting standards. All models are factory performance-tested for a minimum of 16 hours prior to crating.

INSULATION

All cabinet walls, top and bottom have high density, foamed-in-place, non-CFC polyurethane insulation.

SHELVING

Shelves are designed for heavy-duty use with .306" diameter frame and brace members and .140" diameter fill wires spaced 3/4" apart. Shelves are welded steel and epoxy-coated for a durable, long, rust-free service life. Adjustments are in 1 inch increments and a wide door opening allows the use of a variety of optional pan and tray slide types.

CABINET CONSTRUCTION

All materials are of top quality, assembled to conform with strict quality-assurance requirements. The cabinet front is constructed of heavy-gauge polished stainless steel for durability. All cabinet joints and seams are sealed vapor-tight. Case is of all metal, welded construction and internally supported and braced for a rigid unit construction. Cabinet design eliminated overlapping panels with raw edges. Cabinet body is insulated with non-CFC, foamed-in-place polyurethane foam with an average thickness of 3 inches to ensure increased energy efficiency. Full-length louvered air grille located above the doors allows equal air circulation to the condensing unit. Easily removable, low-wattage, anti-sweat door heaters concealed by a non-metallic, non-conductive, high-impact thermal breaker strip eliminate condensate build-up on the cabinet front. Automatic interior lighting is activated by an easily accessible interior switch. Cabinets are equipped with 6 inch adjustable stainless steel legs.

DOOR CONSTRUCTION

Solid hinged door shells are constructed of heavy-gauge stainless steel and are internally braced and urethane-foam-insulated for rigidity. Door corners are welded construction and polished. Replaceable snap-in door gaskets are self-adjusting, heavy-duty, magnetic type. Door handles and hinges are chrome-plated and non-corrosive. Doors are provided with built-in cylinder locks which are keyed alike. Hinges are cam action, lift-off type featuring positive safety stop at 120 degrees.