

WORKTOP REFRIGERATOR

Model: **SW27-BS**

27" Worktop Refrigerator with Solid Door and 6" Backsplash

Stainless steel front and top, aluminum end panels, case back and interior.

Designed to maintain NSF-7 temperatures in 100°F ambient.



Options and Accessories

(upcharge and lead times may apply)

Stainless steel exterior and interior	Glass door - GD models
Stainless back in lieu of aluminum	Expansion valve system
Overshelves (single or double)	Adjustable legs
Additional epoxy-coated steel shelves	Remote models
Stainless steel shelves	Door lock
Automatic electric condensate evaporator	Digital thermometer
Stainless steel roll-out drawers in lieu of door - D models	Special electrical requirements (consult factory)

Consult factory for other model configurations, options and accessories.

Continental
Refrigerator

Toll-Free: 800-523-7138
Phone: 215-244-1400
Fax: 215-244-9579

539 Dunksferry Road
Bensalem, PA 19020
www.continentalrefrigerator.com

Project Name:

Model Specified:

Location:

Item No:

Quantity:

AIA #:

SIS #:

Standard Model Features

REFRIGERATION SYSTEM

- Performance-rated refrigeration system
- Environmentally-safe R-134a refrigerant
- Automatic, energy saving, non-electric condensate evaporator
- Non-corrosive, plasticized fin evaporator coil
- Easily serviceable, back mounted compressor

CABINET ARCHITECTURE

- 2" non-CFC polyurethane foam insulation
- Spring loaded, self closing door
- Magnetic snap-in door gasket
- Heavy-duty, epoxy-coated steel shelf
- Completely enclosed, vented and removable case back
- 5" casters

MODEL FEATURES

- Interior hanging thermometer
- Field rehingeable door

APPROVAL:

Model Specifications

DIMENSIONAL DATA

Net Capacity (cu. ft.)	7.4 (210 cu l)
Width, Overall (in.)	27 1/2 (699 mm)
Depth, Overall (in.) (incl. handle & bumpers)	31 7/16 (799 mm)
Depth, Body Only (less door) (in.)	27 1/2 (699 mm)
Height, Overall (in.) (incl. 5" casters)	40 3/4 (1035 mm)
Shelf Area (sq. ft.)	3.5 (.3 sq m)
No. of Shelves	1
No. of Doors	1
Interior Depth (in.)	See Drawing
Interior Height (in.)	26 1/4 (667 mm)
Interior Width (in.)	24 1/2 (622 mm)

REFRIGERANT DATA

Condensing Unit Size (H.P.)	1/5
Capacity (BTU/Hr)*	1620

ELECTRICAL DATA

Voltage (int'l)	115/60/1 (220/50/1)
Fans	2
Total Amps (int'l)	6.3 (3.7)
10 ft. Cord/Plug [attached] (int'l)	Yes (No)

SHIPPING DATA

Weight (lbs.)	170 (77 kg)
Height - Crated (in.)	43 1/4 (1099 mm)
Width - Crated (in.)	35 3/4 (908 mm)
Depth - Crated (in.)	37 1/4 (946 mm)

* Rating @ +25°F evaporator, 90°F ambient
Figures in parentheses reflect metric equivalents rounded to the nearest whole unit.



Equipped with one NEMA-5-15P Plug
(varies by country)

Model Plan Views

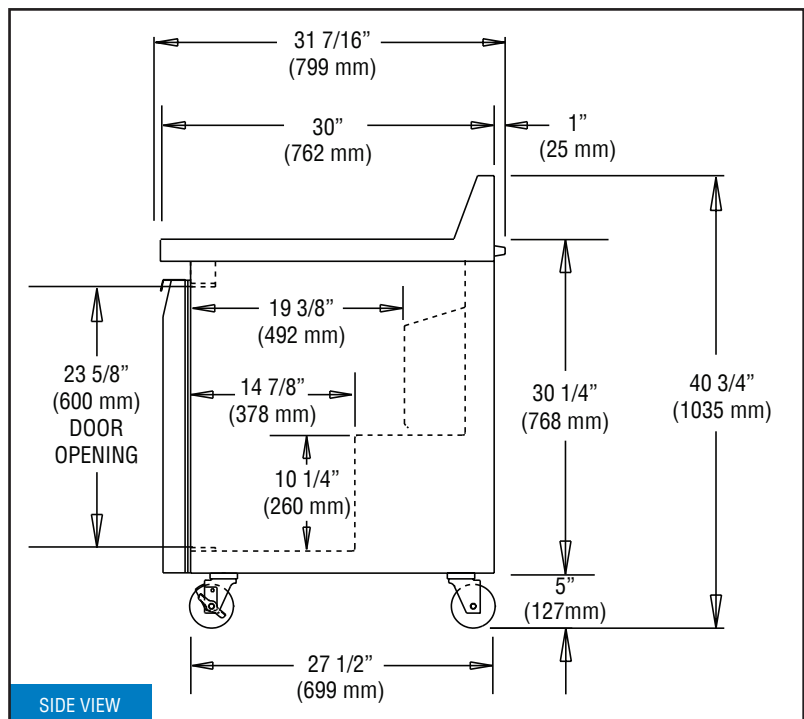
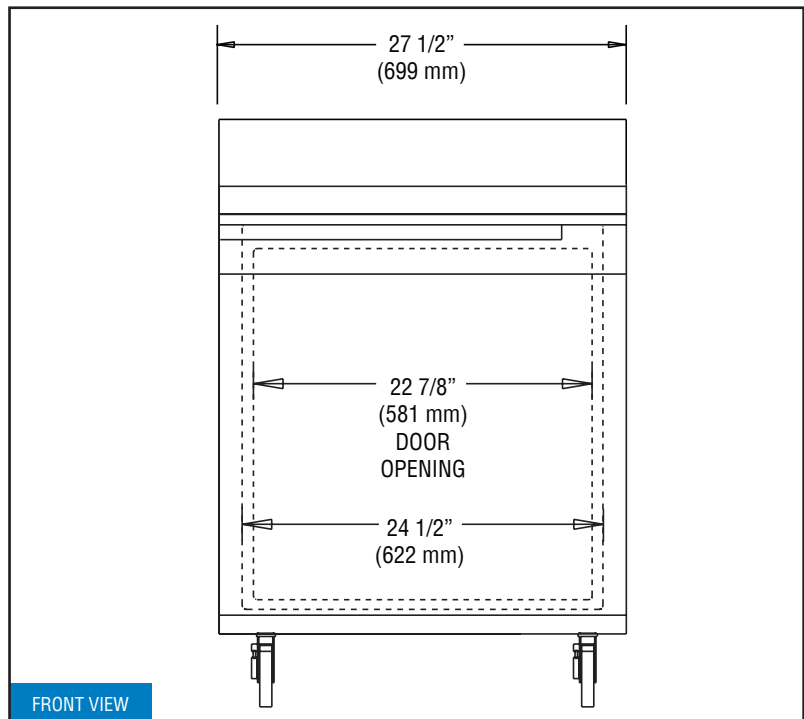

Continental

Refrigerator

Toll-Free: 800-523-7138
Phone: 215-244-1400
Fax: 215-244-9579

539 Dunkserry Road
Bensalem, PA 19020
www.continentalrefrigerator.com

Due to our continued efforts in developing innovative products, specifications subject to change without notice.



MADE IN THE U.S.A.

© Copyright 2013. Continental Refrigerator.
A Division of National Refrigeration & Air Conditioning Products, Inc.