

# UNDERCOUNTER REFRIGERATOR

**Model: SW48-U-D**

## 48" Undercounter Refrigerator with Drawers

Stainless steel front, top and end panels, aluminum back and interior.

Designed to maintain NSF-7 temperatures in 100°F ambient.



### Options and Accessories

(upcharge and lead times may apply)

Stainless steel interior	Automatic electric condensate evaporator
Stainless steel back	Expansion valve system
Solid doors in lieu of drawers	Drawer locks
Glass doors in lieu of drawers	Special electrical requirements (consult factory)

Consult factory for other model configurations, options and accessories.

Project Name:

Model Specified:

Location:

Item No:

Quantity:

AIA #:

SIS #:

### Standard Model Features

#### REFRIGERATION SYSTEM

- Performance-rated refrigeration system
- Environmentally-safe R-134a refrigerant
- Automatic, energy-saving, non-electric condensate evaporator
- Non-corrosive, plasticized fin evaporator coil
- Easily serviceable back mounted compressor

#### CABINET ARCHITECTURE

- 2" non-CFC polyurethane foam insulation
- Stainless steel roll-out drawers
- Magnetic snap-in drawer gaskets
- Completely enclosed, vented and removable case back
- 1 3/8" diameter plate casters (factory installed)

#### MODEL FEATURES

- Electronic controller w/ digital display & hi-low alarm
- 2" high, bottom mounted front breather air divider

**Continental**  
Refrigerator

Toll-Free: 800-523-7138  
Phone: 215-244-1400  
Fax: 215-244-9579

539 Dunksferry Road  
Bensalem, PA 19020  
[www.continentalrefrigerator.com](http://www.continentalrefrigerator.com)

APPROVAL:

## Model Specifications

### DIMENSIONAL DATA

Net Capacity (cu. ft.)	13.4 (379 cu l)
Width, Overall (in.)	48 (1219 mm)
Depth, Overall (in.) (incl. handles & bumpers)	31 9/16 (802 mm)
Height, Overall (in.) (incl. 1 3/8" plate casters)	31 13/16 (808 mm)
No. of Drawers (two tier)	4
No. of Drawers (three tier)	6

### REFRIGERANT DATA

Condensing Unit Size (H.P.)	1/5
Capacity (BTU/Hr)*	1620

### ELECTRICAL DATA

Voltage (int'l)	115/60/1 (220/50/1)
Fans	3
Total Amps (int'l)	7.3 (3.6)
10 ft. Cord/Plug [attached] (int'l)	Yes (No)

### SHIPPING DATA

Weight (lbs.)	248 (112 kg)
Height - Crated (in.)	40 (1016 mm)
Width - Crated (in.)	56 (1422 mm)
Depth - Crated (in.)	37 1/4 (946 mm)

### DRAWER PAN CONFIGURATIONS

**Two Tier:** (1) 12 x 18 x 6 pan per drawer  
or (1) 1/2 size x 6 & (1) 1/3 size x 6 pan per drawer

**Three Tier:** (1) 12 x 18 x 3 1/2 pan per drawer  
or (1) 1/2 size x 4 & (2) 1/3 size x 4 pans per drawer

\* Rating @ +25°F evaporator, 90°F ambient

Figures in parentheses reflect metric equivalents rounded to the nearest whole unit.



Equipped with one NEMA-5-15P Plug  
(varies by country)

## Model Plan Views

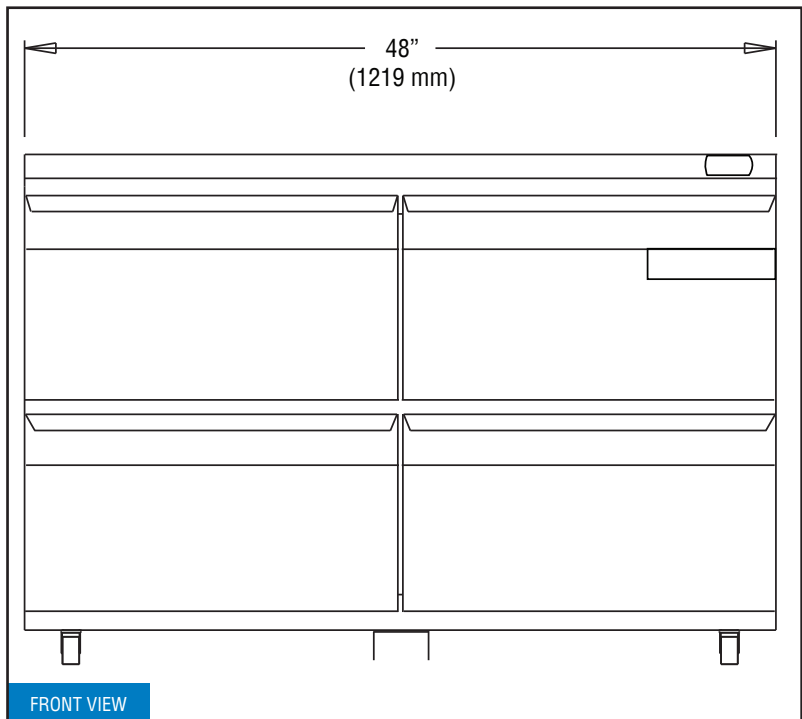

FRONT VIEW

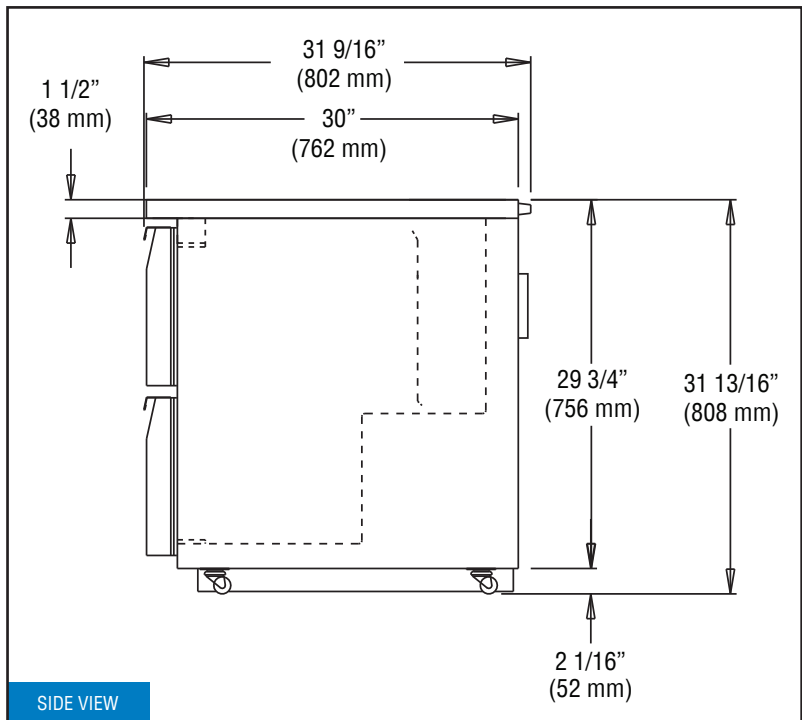

SIDE VIEW

**NOTE:** For proper operation, the area under and in front of the cabinet **must** not be obstructed in any way.

**Continental**  
Refrigerator

Toll-Free: 800-523-7138  
Phone: 215-244-1400  
Fax: 215-244-9579

539 Dunkserry Road  
Bensalem, PA 19020  
[www.continentalrefrigerator.com](http://www.continentalrefrigerator.com)

Due to our continued efforts in developing innovative products, specifications subject to change without notice.



MADE IN THE U.S.A.

© Copyright 2018. Continental Refrigerator.  
A Division of National Refrigeration & Air Conditioning Products, Inc.