

Continental

Designer-line
REFRIGERATORS

Refrigerator

DISPLAY
REFRIGERATORS

Standard Features

Utilizing Environmentally Safe, CFC-free R-134a Refrigerant



DL1R-SS-GD



DL2R-SS-GD



DL3R-SS-GD

Models Available

- Half Door
- Remote
- Pass-Thru
- Consult Factory

- Modern, State-of-the-Art Styling
- Performance rated "Plug" Refrigeration System Utilizing Environmentally Safe R-134a Refrigerant
- 3" Non-CFC Polyurethane Foam Insulation
- Cam-Action Lift-Off Hinges
- Self-Closing Doors
- Magnetic Snap-In Door Gaskets
- Cabinet Upper Side Panels and Refrigeration "Plug" System can be Easily Removed and Reinstalled at Job-Site Where Space Limitations are Confining
- Cylinder Lock In Each Door
- Automatic Hot Gas Condensate Evaporator
- Refrigeration System is Readily Accessible on Top of the Cabinet and Separate from the Food Zone to Increase Food Storage Capacity
- Adjustable 6" Stainless Steel Legs
- Heavy-Duty, Epoxy-Coated Steel Shelves
- External Digital Thermometer
- Double-pane, Tempered Hinged Glass Doors
- Fluorescent Interior Lighting

Standard (S/S Front, Aluminum Ends & Interior)
Suffix SA (S/S Exterior, Aluminum Interior)
Suffix SS (S/S Exterior & Interior)

Refrigeration System

A "Performance Rated", air cooled, hermetically sealed, capillary-type refrigeration system is installed on the top of each refrigerator. Plasticized fin coil and air circulating fans are contained within a concealed "plug" type insulated housing, readily accessible on top of the cabinet and separate from the food zone to increase food storage capacity. The entire "plug" system is fully charged with environmentally safe R-134a refrigerant and mounted on a sturdy steel, rail-type base which can be easily removed if freezer conversion is desired. Refrigerators are designed to maintain 38 to 40 degrees Fahrenheit (3 to 5 degrees Centigrade) while operating with an unrestricted air supply in a maximum ambient temperature of 100 degrees Fahrenheit. All condensate water is evaporated by an automatic non-electric, corrosion-resistant condensate evaporator. A strict quality-assurance team inspects all materials and components to certify that each model conforms to the most exacting standards. All models are factory performance tested for a minimum of 16 hours prior to crating.

Cabinet Construction

All materials are of top quality, assembled to conform with strict quality-assurance requirements. The cabinet front is constructed of heavy-gauge polished stainless steel for durability. All cabinet joints and seams are sealed vapor-tight. Case is of all metal, welded construction and internally supported and braced for a rigid unit construction. Cabinet design eliminates overlapping panels with raw edges. Cabinet body is insulated with non-CFC, foamed-in-place polyurethane foam with an average thickness of 3 inches to ensure increased energy efficiency. Full length louvered air grille located above the doors allows equal air circulation to the condensing unit. Easily removable, low wattage, anti-sweat door heaters concealed by a non-metallic, non-conductive, high-impact thermal breaker strip eliminate condensate build-up on the cabinet front. Fluorescent lighting is activated by an easily accessible interior switch. Cabinets are equipped with 6-inch adjustable stainless steel legs.

Shelving

Shelves are designed for heavy-duty use with .306" diameter frame and brace members and .140" diameter fill wires spaced 3/4" apart. Shelves are welded steel and epoxy-coated for a durable, long, rust-free service life. Adjustments are in 1/2" increments and a wide door opening allows the use of a variety of optional pan and tray slide types.

Door Construction

Double-pane tempered glass is encased by a heated, heavy-duty aluminum extruded frame. Replaceable snap-in door gaskets are self-adjusting, heavy-duty, magnetic type. Door handles and hinges are chrome-plated and non-corrosive. Doors are provided with built-in cylinder locks which are keyed alike. Hinges are cam-action, lift-off type featuring positive safety stop at 120 degrees.



c



CHARACTERISTICS	DL1R-SS-GD		DL2R-SS-GD		DL3R-SS-GD	
	Reach-In	Pass-Thru	Reach-In	Pass-Thru	Reach-In	Pass-Thru
	(Glass One Side)				(Glass One Side)	
DIMENSIONAL DATA						
Net Capacity (cu. ft.)	21	21	50	50	72	72
Width, Overall (in.)	26	26	52	52	78	78
Depth, Overall (Incl. Hdls.) (in.)	35 ¹ / ₂	39	35 ¹ / ₂	39	35 ¹ / ₂	39
Depth (Less Door(s) (in.)	32	32	32	32	32	32
Depth (Doors(s) Open 90°) (in.)	55 ¹ / ₂	79	55 ¹ / ₂	79	55 ¹ / ₂	79
Clear Door Width (in.)	19 ³ / ₈	19 ³ / ₈	19 ³ / ₈	19 ³ / ₈	19 ³ / ₈	19 ³ / ₈
Clear Full-Door Height (in.)	58 ⁵ / ₈	58 ⁵ / ₈	58 ⁵ / ₈	58 ⁵ / ₈	58 ⁵ / ₈	58 ⁵ / ₈
Clear Half-Door Height (in.)	27 ¹ / ₂	27 ¹ / ₂	27 ¹ / ₂	27 ¹ / ₂	27 ¹ / ₂	27 ¹ / ₂
Height, Overall (Inc. 6" Legs)(in.)	83 ¹ / ₄	83 ¹ / ₄	83 ¹ / ₄	83 ¹ / ₄	86 ³ / ₄	86 ³ / ₄
Full Door(s)	1	2	2	4	3	6
Half Door(s)	2	4	4	8	6	12
Shelves	4	4	8	8	12	12
Shelf Area (sq. ft.)	23.8	23.8	47.6	47.6	71.4	71.4
Tray Slide Capacity (Half)	12 ea.	12 ea.	12 ea.	12 ea.	12 ea.	12 ea.
Tray Slide Capacity (Full)	24 ea.	24 ea.	24 ea.	24 ea.	24 ea.	24 ea.
REFRIGERATION DATA						
Condensing Unit Size (H.P.)	1/3	1/3	1/2	1/2	3/4	3/4
Capacity (BTU/hr)**	2560	2560	4010	4010	5930	5930
ELECTRICAL DATA						
Cabinet Specifications	115/60/1	115/60/1	115/60/1	115/60/1	115/208-230/60/1	115/208-230/60/1
Feed Wires (Incl. Ground)	3	3	3	3	4	4
Condensing Unit Specs.	115/60/1	115/60/1	115/60/1	115/60/1	208-230/60/1	208-230/60/1
Total Amperes	10.7	11	13.6	16.0	12.8	15.9
Cabinet Amperes	3.5	3.8	4.1	6.5	5.8	8.9
Defrost Amperes	-	-	-	-	-	-
Power Supply Cord	yes	yes	yes	yes	no	no
SHIPPING DATA						
Height – crated (in.)	85 ¹ / ₂	85 ¹ / ₂	85 ¹ / ₂	85 ¹ / ₂	85 ¹ / ₂	85 ¹ / ₂
Width – crated (in.)	31 ⁵ / ₈	31 ⁵ / ₈	64	64	90	90
Depth – crated (in.)	42	42	42	42	42	42
Volume – crated (cu.ft.)	66	66	133	133	187	187
Weight Std – crated (lbs.)	325	390	545	645	755	930
Weight SS – crated (lbs.)	385	440	675	725	870	1045
Weight Std – uncrated (lbs.)	225	260	375	445	545	650
Weight SS – uncrated (lbs.)	285	370	455	525	660	765

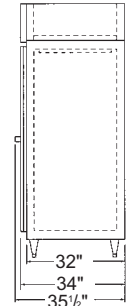

SIDE VIEW

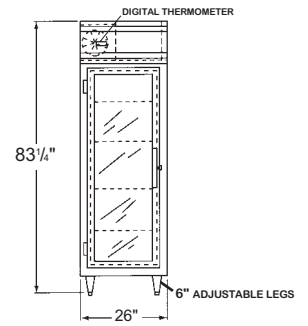

DL1R-SS-GD
FRONT VIEW

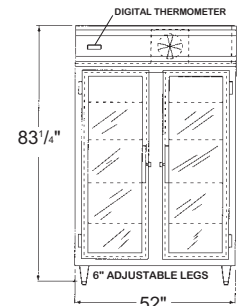

DL2R-SS-GD
FRONT VIEW

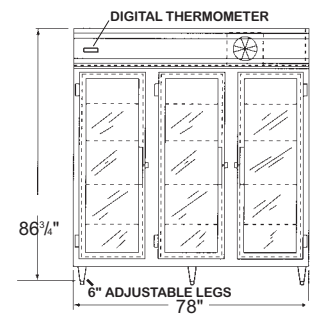

DL3R-SS-GD
FRONT VIEW

**Rating @ +25°F Evaporator, 90° Ambient

Note: All specifications subject to change without notice.

Note: If the cabinet is located directly against wall and/or under low ceiling, a minimum clearance of 12" is required. Cabinet upper side panels and refrigeration plug system can be easily removed and reinstalled at installation site where space limitations are confining.