

Continental

Designer-line
WARMERS

Refrigerator

**ROLL-IN & ROLL-THRU
WARMERS
90° TO 180° RANGE**

Standard Features

- Modern, State-of-the-Art Styling
- Top Mounted Heating Plenum "Plug" Design with Circulating Fans for Uniform Temperature Distribution
- Humidity Relief Vent
- 27³/₈" Wide, 66¹/₂" High Door Openings
- 3" Non-CFC Polyurethane Foam Insulation
- Cam-Action Lift-Off Hinges
- Self-Closing Doors
- Automatic Interior Lighting
- Cylinder Lock In Each Door
- Exterior Thermostat Control with master On/Off Control Switch
- Removable Stainless Steel Ramps
- Magnetic Snap-In Door Gasket
- Exterior Digital Thermometer
- Removable Stainless Steel Rack Guides



Models Available

- Roll-Thru
- Consult Factory

Standard (S/S Front, Aluminum Ends & Interior)
Suffix SA (S/S Exterior, Aluminum Interior)
Suffix SS (S/S Exterior & Interior)

Heating System-(Range 90°F to 180°F)

Electrically operated heating system is controlled by means of a highly sensitive calibrated thermostat mounted on the cabinet front. Fin strip heating elements are located at the base of the interior. Air circulating blower located in a top mounted, concealed "plug" housing distributes heat throughout product zone, assuring uniform cabinet temperatures. Cabinet top has a built-in humidity relief vent. The entire "plug" system is mounted on a sturdy steel, rail-type base which can be easily removed if refrigerator or freezer conversion is desired. A strict quality assurance team inspects all material and components to certify that each model conforms to the most exacting standards. All models are factory performance tested for a minimum of 16 hours prior to crating.

Cabinet Construction

All materials are of top quality, assembled to conform with strict quality-assurance requirements. The cabinet front and doors are constructed of heavy-gauge polished stainless steel for durability. All cabinet joints and seams are sealed vapor-tight. Case is of all metal, welded construction and internally supported and braced for a rigid unit construction. Cabinet design eliminates overlapping panels with raw edges. Cabinet body and doors are insulated with non-CFC, foamed-in-place polyurethane foam with an average thickness of 3 inches to ensure increased energy efficiency. Automatic interior lighting is controlled by door openings. Cabinets are equipped with an easily removable, stainless steel ramp and interior rack guides.

Door Construction

Door shells are constructed of heavy-gauge stainless steel and are internally braced and urethane-foam-insulated for rigidity. Door corners are of welded construction and polished. Door gaskets are self-adjusting, heavy-duty, magnetic type. Door handles and hinges are chrome-plated and non-corrosive. Doors are provided with built-in cylinder locks which are keyed alike. Hinges are cam action, lift-off type featuring positive safety stop at 120 degrees.





CHARACTERISTICS	DL1WI-SS One Section		DL2WI-SS Two Section		DL3WI-SS Three Section	
	Roll-In	Roll-Thru	Roll-In	Roll-Thru	Roll-In	Roll-Thru
DIMENSIONAL DATA						
Net Capacity (cu. ft.)	32	32	64	64	96	96
Width, Overall (in.)	35 ¹ / ₄	35 ¹ / ₄	68 ¹ / ₂	68 ¹ / ₂	101 ³ / ₄	101 ³ / ₄
Depth, Overall (Incl. Hlds.) (in.)	35 ¹ / ₂	39	35 ¹ / ₂	39	35 ¹ / ₂	39
Depth (Less Door(s)) (in.)	32	32	32	32	32	32
Depth (Doors(s) Open 90°) (in.)	65	98	65	98	65	98
Clear Door Width (in.)	27 ³ / ₈	27 ³ / ₈	27 ³ / ₈	27 ³ / ₈	27 ³ / ₈	27 ³ / ₈
Clear Full-Door Height (in.)	66 ¹ / ₂	66 ¹ / ₂	66 ¹ / ₂	66 ¹ / ₂	66 ¹ / ₂	66 ¹ / ₂
Height, Overall (in.)	86	86	86	86	86	86
No. of Full Door(s)	1	2	2	4	3	6
Rack Capacity*	1	1	2	2	3	3

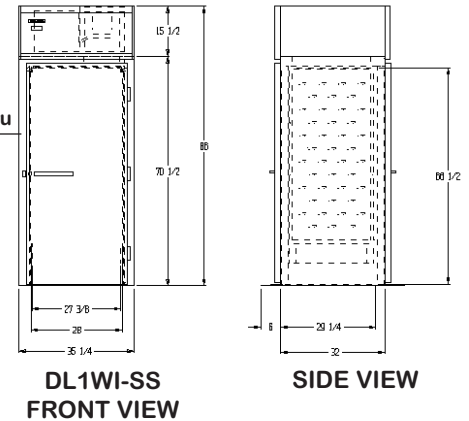

ELECTRICAL DATA

Cabinet Specifications	115/208-230/60/1	115/208-230/60/1	115/208-230/60/1	115/208-230/60/1	115/208-230/60/1	115/208-230/60/1
Feed Wires (Incl. Ground)	4	4	4	4	4	4
Total Amperes	7.8	7.8	14.5	14.5	22.4	22.4
Total Wattage @ 208-230 Volts	1500	1500	3000	3000	4500	4500
Power Supply Cord	no	no	no	no	no	no

SHIPPING DATA

Height – crated (in.)	90	90	90	90	90	90
Width – crated (in.)	43	43	77	77	109	109
Depth – crated (in.)	42	42	42	42	42	42
Volume – crated (cu.ft.)	94	94	168	168	238	238
Weight Std – crated (lbs.)	415	475	680	780	840	960
Weight SS – crated (lbs.)	505	580	720	825	925	1050
Weight Std – uncrated (lbs.)	330	380	540	625	670	760
Weight SS – uncrated (lbs.)	405	460	575	660	740	840

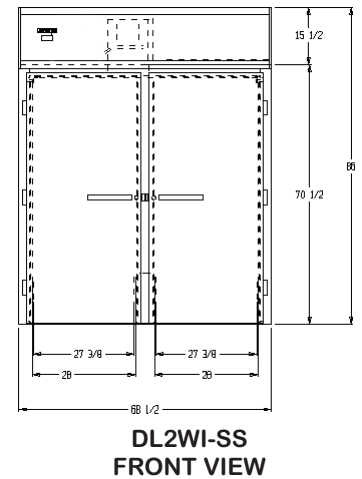

* Maximum Rack Size Including Wheels – 27" Wide x 29" Deep x 66 1/4" High

Note: All specifications subject to change without notice.

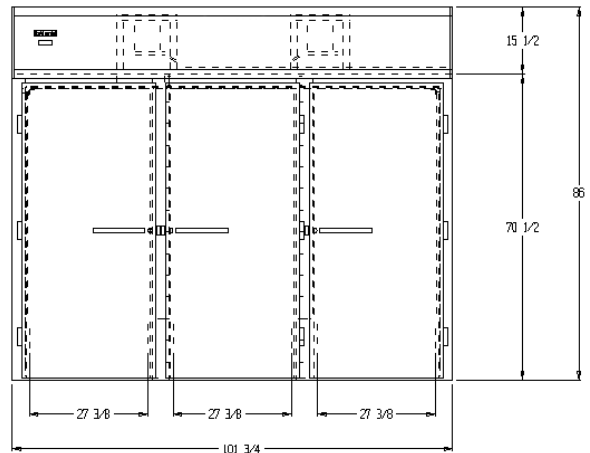

**DL3WI-SS
FRONT VIEW**



A Division of National Refrigeration & A/C Products, Inc.
 539 Dunksferry Road Bensalem, PA 19020
 (800) 523-7138 Fax: (215) 244-9579
 www.continentalrefrigerator.com