

Continental

Refrigerator

REACH-IN LOW TEMP FREEZERS

Standard Features

- Modern, State-of-the-Art Styling Performance Rated Refrigeration System Designed for -15°F Cabinet – Ideal for Ice Cream
- 3" Non-CFC Polyurethane Foam Insulation
- Chrome Plated Flow Line Handles
- Cam-Action Lift-Off Hinges
- Self-Closing Doors
- Automatic Interior Lighting
- Magnetic Snap-In Door Gasket
- Cylinder Lock in Each Door
- Automatic Electric Condensate Evaporator
- 5" Casters
- Heavy-Duty, Epoxy-Coated Steel Shelves
- External Dial Thermometer
- Automatic Electric Defrost
- Thermal Expansion Valve Governs Refrigerant Flow for Quick Recovery

Standard (S/S Front, Aluminum End Panels & Interior)
Suffix SA (S/S Exterior, Aluminum Interior)
Suffix SS (S/S Exterior & Interior)

Optional Features & Accessories

- Half Door
- Shallow Depth
- Stainless Steel Shelves
- Digital Thermometer
- Pan Slide Assemblies
- Increased Refrigeration Systems
- Remote
- Hinged Glass Doors
- Legs
- Rehinging of Doors
- Stainless Steel Case Back



1F-LT



3F-LT



2F-LT

Utilizing Environmentally Safe, CFC-free R-404A Refrigerant



Reach-In Low-Temp Freezers

| SPECIFICATIONS | 1F-LT | 2F-LT | 3F-LT |
|--|--------------------------------|--------------------------------|--------------------------------|
| | One Section | Two Section | Three Section |
| CHARACTERISTICS | Reach-In | Reach-In | Reach-In |
| DIMENSIONAL DATA | | | |
| Net Capacity (cu. ft.) | 20 | 48 | 70 |
| Width, Overall (in.) | 26 | 52 | 78 |
| Depth, Overall (Incl. Hdls.) (in.) | 35 ¹ / ₂ | 35 ¹ / ₂ | 35 ¹ / ₂ |
| Depth (Less Door(s)) (in.) | 32 | 32 | 32 |
| Depth (Doors(s) Open 90°) (in.) | 55 ¹ / ₂ | 55 ¹ / ₂ | 55 ¹ / ₂ |
| Clear Door Width (in.) | 19 ³ / ₈ | 19 ³ / ₈ | 19 ³ / ₈ |
| Clear Full-Door Height (in.) | 58 ⁵ / ₈ | 58 ⁵ / ₈ | 58 ⁵ / ₈ |
| Clear Half-Door Height (in.) | 27 ¹ / ₂ | 27 ¹ / ₂ | 27 ¹ / ₂ |
| Height, Overall (Inc. 5" Casters)(in.) | 85 ³ / ₄ | 85 ³ / ₄ | 85 ³ / ₄ |
| No. of Full Door(s) | 1 | 2 | 3 |
| No. of Half Door(s) | 2 | 4 | 6 |
| No. of Shelves | 3 | 6 | 9 |
| Shelf Area (sq. ft.) | 20.4 | 40.8 | 61.2 |
| Tray Slide Capacity (Half) | 11 ea. | 11 ea. | 11 ea. |
| Tray Slide Capacity (Full) | 24 ea. | 24 ea. | 24 ea. |
| REFRIGERATION DATA | | | |
| Condensing Unit Size (H.P.) | ³ / ₄ | 1 | 2 |
| Capacity (BTU/Hr)* | 2050 | 3175 | 6300 |

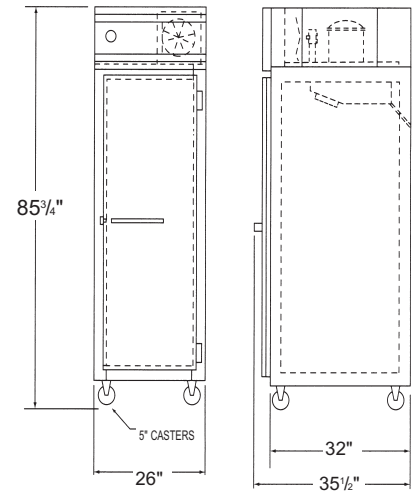

| ELECTRICAL DATA | 115/208-230/60/1 | 115/208-230/60/1 | 115/208-230/60/1 |
|---------------------------|------------------|------------------|------------------|
| Cabinet Specifications | 115/208-230/60/1 | 115/208-230/60/1 | 115/208-230/60/1 |
| Feed Wires (Incl. Ground) | 4 | 4 | 4 |
| Condensing Unit Specs. | 208-230/60/1 | 208-230/60/1 | 208-230/60/1 |
| Total Amperes | 10.8 | 13.1 | 20.0 |
| Cabinet Amperes | 1.6 | 2.7 | 3.6 |
| Defrost Amperes | 5.2 | 9.6 | 10.4 |
| Power Supply Cord | no | no | no |

| SHIPPING DATA | 1F-LT | 2F-LT | 3F-LT |
|------------------------------|--------------------------------|--------------------------------|--------------------------------|
| Height – crated (in.) | 85 ¹ / ₂ | 85 ¹ / ₂ | 85 ¹ / ₂ |
| Width – crated (in.) | 31 ⁵ / ₈ | 64 | 90 |
| Depth – crated (in.) | 42 | 42 | 42 |
| Volume – crated (in.) | 65 | 133 | 187 |
| Weight Std – crated (lbs.) | 450 | 565 | 810 |
| Weight SS – crated (lbs.) | 510 | 645 | 925 |
| Weight Std – uncrated (lbs.) | 350 | 395 | 600 |
| Weight SS – uncrated (lbs.) | 410 | 475 | 715 |

* Rating @ -30°F Evaporator, 90° Ambient

Note: All specifications subject to change without notice.

Note: If the cabinet is located directly against wall and/or under low ceiling, a minimum clearance of 12" is required.

Continental

Refrigerator

A Division of National Refrigeration & A/C Products, Inc.
 539 Dunksferry Road Bensalem, PA 19020
 (800) 523-7138 Fax: (215) 244-9579
www.continentalrefrigerator.com

