

Continental

Refrigerator

**OVER/UNDER
DUAL TEMP
REFRIGERATOR/FREEZER**



Models Available

- 1RF
- 1RFE
- 1RFX

Utilizing Environmentally Safe, CFC-free R-134a & R-404A Refrigerant

Standard Features

- Modern, State-of-the-Art Styling
- 3" Non-CFC Polyurethane Foam Insulation
- Performance Rated Refrigeration Systems Utilizing Non-CFC Refrigerants
- Chrome Plated Flow Line Handles
- Cam-Action Lift-Off Hinges
- Self-Closing Doors
- Automatic Interior Lighting
- Magnetic Snap-In Door Gasket
- Cylinder Lock In Each Door
- Automatic Electric Condensate Evaporator
- 5" Casters
- Heavy-Duty, Epoxy-Coated Steel Shelves
- External Dial Thermometers
- Automatic Electric Defrost on Freezer Section

Standard (S/S Front, Aluminum Ends & Interior)
Suffix SA (S/S Exterior, Aluminum Interior)
Suffix SS (S/S Exterior & Interior)

Optional Features & Accessories

- Legs
- Pan Slide Assemblies
- Stainless Steel Shelves
- Rehinging of Doors
- Glass Doors
- Stainless Steel Case Back
- Digital Thermometer
- Remote



c



Over / Under Dual Temp Refrigerator / Freezer

CHARACTERISTICS DIMENSIONAL DATA

	1RF Reach-In	1RFX Reach-In	1RFE Reach-In
Net Capacity (cu. ft.) Refrigerator	10	16	11
Net Capacity (cu.ft.) Freezer	10	16	11
Width, Overall (in.)	26	36 ¹ / ₄	28 ¹ / ₂
Depth, Overall (Incl. Hdl.) (in.)	35 ¹ / ₂	35 ¹ / ₂	35 ¹ / ₂
Depth (Less Door(s) (in.)	32	32	32
Depth (Doors(s) Open 90°) (in.)	55 ¹ / ₂	66	58
Clear Door Width (in.)	19 ³ / ₈	29 ⁵ / ₈	21 ⁷ / ₈
Clear Half-Door Height (in.)	27 ¹ / ₂	27 ¹ / ₂	27 ¹ / ₂
Height, Overall (Incl. 5" Casters)(in.)	82 ¹ / ₄	82 ¹ / ₄	82 ¹ / ₄
Half Doors	2	2	2
Shelves	4	4	4
Shelf Area (sq. ft.)	10.2	24.4	10.2
Tray Slide Capacity (Half)	11ea.	11ea.	11ea.
REFRIGERATION DATA			
Condensing Unit Size (H.P.) Ref.	1/5	1/4	1/5
Condensing Unit Size (H.P.) Frz.	1/4	1/3	1/4
Capacity (BTU/hr)*Ref.	1725	1940	1725
Capacity (BTU/hr)*Frz.	1250	1590	1250
ELECTRICAL DATA			
Cabinet Specifications	115/60/1	115/60/1	115/60/1
Feed Wires (Incl. Ground)	3/3	3/3	3/3
Condensing Unit Specs.	115/60/1	115/60/1	115/60/1
Total Amperes	5.3/5.4	6.9/7.6	5.3/5.4
Cabinet Amperes	.9/.9	1.6/1.6	.9/.9
Defrost Amperes	5.2	6.5	5.2
Power Supply Cord	yes/yes	yes/yes	yes/yes
SHIPPING DATA			
Height – crated (in.)	85 ¹ / ₂	85 ¹ / ₂	85 ¹ / ₂
Width – crated (in.)	31 ⁵ / ₈	42	31 ⁵ / ₈
Depth – crated (in.)	42	42	42
Volume – crated (cu.ft.)	66	87	66
Weight Std – crated (lbs.)	420	440	420
Weight SS – crated (lbs.)	480	500	480
Weight Std – uncrated (lbs.)	320	340	320
Weight SS – uncrated (lbs.)	380	400	380

*Rating @ +25°F Evaporator, 90° Ambient (Refrigerator)

*Rating @ -15°F Evaporator, 90° Ambient (Freezer)

Note: All specifications subject to change without notice

Note: If the cabinet is located directly against wall and/or under low ceiling, a minimum clearance of 12" is required.

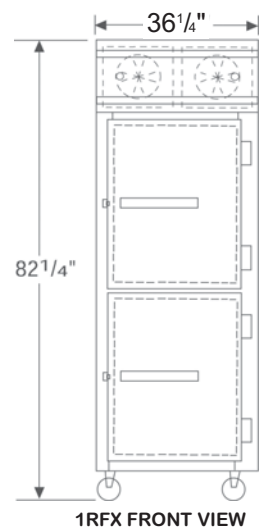
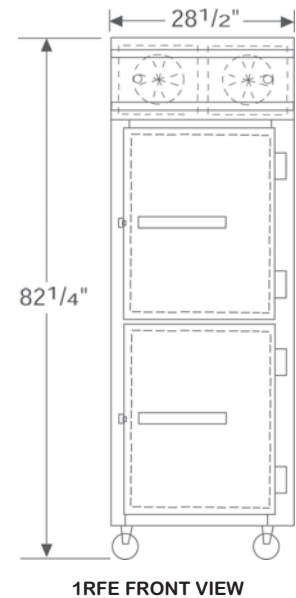
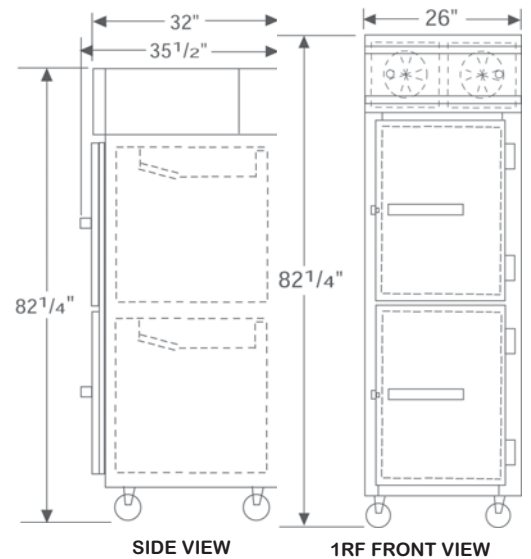

A Division of National Refrigeration & A/C Products, Inc.
539 Dunksferry Road Bensalem, PA 19020
(800) 523-7138 Fax: (215) 244-9579
www.continentalrefrigerator.com