

DESIGNER LINE WARMER

Model: DL1WE-PT

Designer Line

1-Section Extra-Wide Pass-Thru Warmer

DL1WE-PT - Stainless steel front, aluminum end panels and interior
DL1WE-SA-PT - Stainless steel exterior, aluminum interior
DL1WE-SS-PT - Stainless steel exterior and interior



Options and Accessories

(upcharge and lead times may apply)

Additional chrome plated steel shelves	Rehinging of doors (consult factory)
Stainless steel shelves	Special electrical req. (consult factory)
Pan slide assemblies	Correctional Facility Options
Casters	<ul style="list-style-type: none"> One way security screws
Custom laminates	<ul style="list-style-type: none"> Locking hasp (lock not included)
Half doors	<ul style="list-style-type: none"> Stainless steel mesh cover
Hinged glass doors (consult factory)	<ul style="list-style-type: none"> Coverless hinges

Consult factory for other model configurations, options and accessories.

Continental
Refrigerator

Toll-Free: 800-523-7138
 Phone: 215-244-1400
 Fax: 215-244-9579

539 Dunksferry Road
 Bensalem, PA 19020
www.continentalrefrigerator.com

Project Name:

Model Specified:

Location:

Item No:

Quantity:

AIA #:

SIS #:

Standard Model Features

HEATING SYSTEM

Self contained, performance rated heating system
 90°F to 180°F temperature range
 Top mounted heating plenum "plug" with circulating fan
 Unique air flow distribution ducts

CABINET ARCHITECTURE

3" non-CFC polyurethane foam insulation
 Smooth, polished chrome workflow door handles
 Cam action, lift off hinges
 Self-closing doors
 Magnetic snap in Santoprene™ door gaskets
 Cylinder lock in each door
 Heavy duty, chrome plated steel shelves
 Heavy duty pilaster strips
 Adjustable 6" stainless steel legs

MODEL FEATURES

Automatic interior lighting
 Electronic controller with digital display & hi-low alarm
 Stainless steel strip heaters located in base of interior

APPROVAL:

Model Specifications

DIMENSIONAL DATA

Net Capacity (cubic feet)	22 (623 cu l)
Width, Overall (inches)	28 1/2 (724 mm)
Depth, Overall (inches) (including handle)	38 3/4 (984 mm)
Depth (inches) (less door)	32 (813 mm)
Depth (inches) (door open 90°)	84 (2134 mm)
Clear Door Width (inches)	21 7/8 (556 mm)
Clear Door Height (inches)	58 5/8 (1489 mm)
Height, Overall (inches) (including 6" legs)	83 1/4 (2115 mm)
Number of Doors	2
Number of Shelves	3
Shelf Area (square feet)	22.2 (2.1 sq m)
Tray Slide Capacity	19

ELECTRICAL DATA

Voltage	208-230/60/1
Feed Wires (including ground)	3
Total Amps (International)	7.2 (7.2)
Total Wattage @ 208-230 volts	1500
10 ft. Cord/Plug (International)	No (No)

SHIPPING DATA

Height - Crated (inches)	85 1/2 (2172 mm)
Width - Crated (inches)	31 5/8 (803 mm)
Depth - Crated (inches)	42 (1067 mm)
Volume - Crated (cubic feet)	65 (1841 cu l)
Weight Std - Crated (pounds)	320 (145 kg)
Weight SS - Crated (pounds)	336 (152 kg)

Figures in parentheses reflect metric equivalents rounded to the nearest whole unit.

Model Plan Views

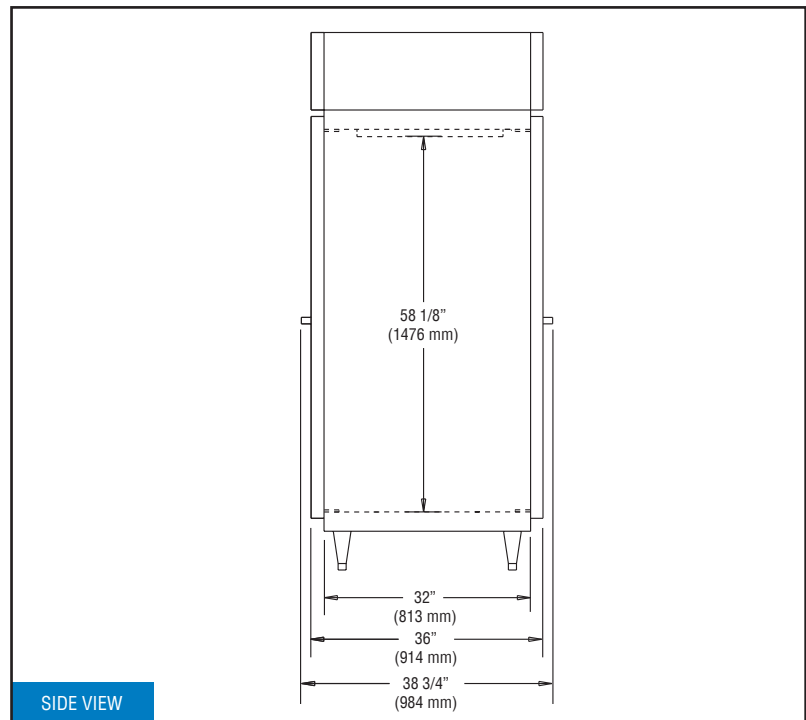
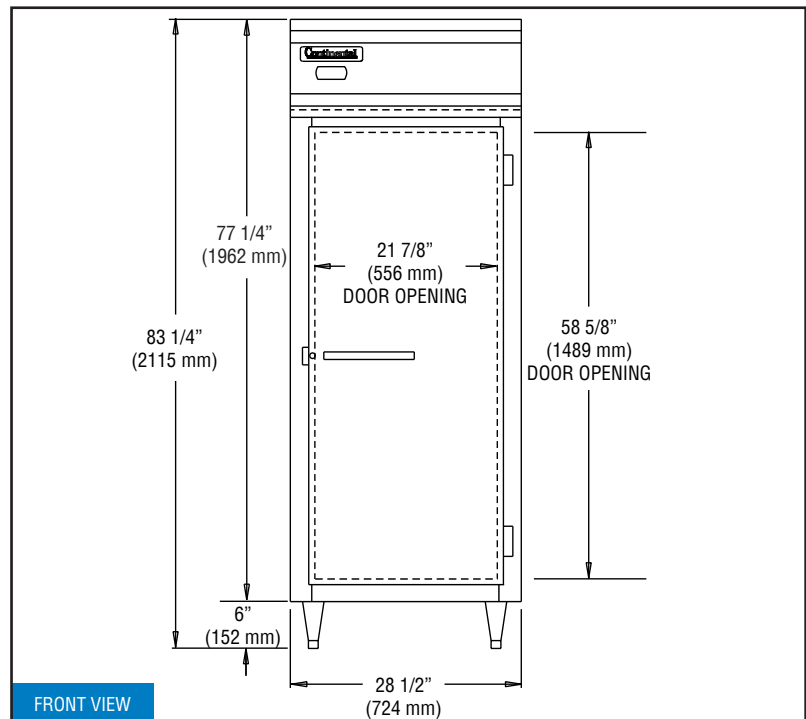

IMPORTANT NOTE: If the cabinet is located directly against a wall and/or under a low ceiling, a minimum clearance of 12" is required on top and 3" on sides and rear.

Continental
Refrigerator

Toll-Free: 800-523-7138
Phone: 215-244-1400
Fax: 215-244-9579

539 Dunksferry Road
Bensalem, PA 19020
www.continentalrefrigerator.com

Due to our continued efforts in developing innovative products, specifications subject to change without notice.

